

# Pull-reset Safety Limit Switch D4N-□□□R

## A Series of Pull-reset Models Now Available

- Lineup includes three contact models with 2NC/1NO and 3NC contact forms in addition to the previous contact forms 1NC/1NO and 2NC.
- M12-connector models are available, saving on labor and simplifying replacement.
- Standardized gold-clad contacts provide high contact reliability. Can be used with both standard loads and microloads.
- Free of lead, cadmium, and hexavalent chrome, reducing the burden on the environment.
- Conforms to EN115 and EN81-1.
- Approved standards: UL, EN (TÜV), and CCC

**Note:** Be sure to read the "Safety Precautions" on page B-66.

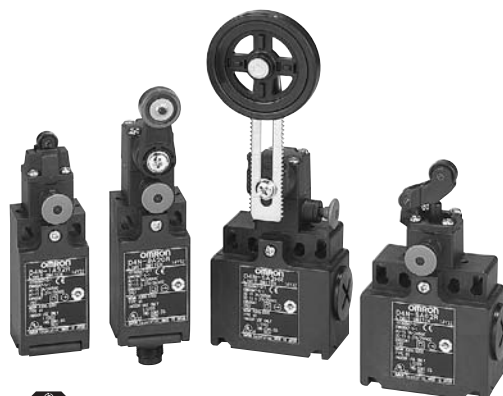

**NEW**

**Note:** Contact your sales representative for details on models with safety standard certification.

Safety Limit  
Switches  
D4N-□□R

## Model Number Structure

### ■ Model Number Legend

D4N-□□□□R  
1 2 3

#### 1. Conduit/Connector size

- 1: Pg13.5 (1-conduit)
- 2: G1/2 (1-conduit)
- 3: 1/2-14NPT (1-conduit)
- 4: M20 (1-conduit)
- 5: Pg13.5 (2-conduit)
- 6: G1/2 (2-conduit)
- 7: 1/2-14NPT (M20 2-conduit with 1/2-14NPT changing adaptor included)
- 8: M20 (2-conduit)
- 9: M12 connector (1-conduit)

#### 2. Built-in Switch





- A: 1NC/1NO (slow-action)
- B: 2NC (slow-action)
- C: 2NC/1NO (slow-action)
- D: 3NC (slow-action)

#### 3. Head and Actuator



- 20: Roller lever (resin lever, resin roller)
- 2G: Adjustable roller lever, form lock (metal lever, resin roller)
- 2H: Adjustable roller lever, form lock (metal lever, rubber roller)
- 31: Top plunger
- 32: Top roller plunger
- 62: One-way roller arm lever (horizontal)
- 72: One-way roller arm lever (vertical)

# Ordering Information

## List of Models

Actuator	Conduit size		Built-in switch mechanism			
			1NC/1NO (Slow-action)	2NC (Slow-action)	2NC/1NO (Slow-action)	3NC (Slow-action)
Roller lever (resin lever, resin roller) 	1-conduit	Pg13.5	D4N-1A20R	D4N-1B20R	D4N-1C20R	D4N-1D20R
		G1/2	D4N-2A20R	D4N-2B20R	D4N-2C20R	D4N-2D20R
		1/2-14NPT	D4N-3A20R	D4N-3B20R	D4N-3C20R	D4N-3D20R
		M20	D4N-4A20R	D4N-4B20R	D4N-4C20R	D4N-4D20R
		M12 connector	D4N-9A20R	D4N-9B20R	---	---
	2-conduit	Pg13.5	D4N-5A20R	D4N-5B20R	D4N-5C20R	D4N-5D20R
		G1/2	D4N-6A20R	D4N-6B20R	D4N-6C20R	D4N-6D20R
		1/2-14NPT (See note 2.)	D4N-7A20R	D4N-7B20R	D4N-7C20R	D4N-7D20R
		M20	D4N-8A20R	D4N-8B20R	D4N-8C20R	D4N-8D20R
		M12 connector	D4N-9A20R	D4N-9B20R	---	---
Adjustable roller lever, form lock (metal lever, resin roller) 	1-conduit	Pg13.5	D4N-1A2GR	D4N-1B2GR	D4N-1C2GR	D4N-1D2GR
		G1/2	D4N-2A2GR	D4N-2B2GR	D4N-2C2GR	D4N-2D2GR
		1/2-14NPT	D4N-3A2GR	D4N-3B2GR	D4N-3C2GR	D4N-3D2GR
		M20	D4N-4A2GR	D4N-4B2GR	D4N-4C2GR	D4N-4D2GR
		M12 connector	D4N-9A2GR	D4N-9B2GR	---	---
	2-conduit	Pg13.5	D4N-5A2GR	D4N-5B2GR	D4N-5C2GR	D4N-5D2GR
		G1/2	D4N-6A2GR	D4N-6B2GR	D4N-6C2GR	D4N-6D2GR
		1/2-14NPT (See note 2.)	D4N-7A2GR	D4N-7B2GR	D4N-7C2GR	D4N-7D2GR
		M20	D4N-8A2GR	D4N-8B2GR	D4N-8C2GR	D4N-8D2GR
		M12 connector	D4N-9A2GR	D4N-9B2GR	---	---
Adjustable roller lever, form lock (metal lever, rubber roller) 	1-conduit	Pg13.5	D4N-1A2HR	D4N-1B2HR	D4N-1C2HR	D4N-1D2HR
		G1/2	D4N-2A2HR	D4N-2B2HR	D4N-2C2HR	D4N-2D2HR
		1/2-14NPT	D4N-3A2HR	D4N-3B2HR	D4N-3C2HR	D4N-3D2HR
		M20	D4N-4A2HR	D4N-4B2HR	D4N-4C2HR	D4N-4D2HR
		M12 connector	D4N-9A2HR	D4N-9B2HR	---	---
	2-conduit	Pg13.5	D4N-5A2HR	D4N-5B2HR	D4N-5C2HR	D4N-5D2HR
		G1/2	D4N-6A2HR	D4N-6B2HR	D4N-6C2HR	D4N-6D2HR
		1/2-14NPT (See note 2.)	D4N-7A2HR	D4N-7B2HR	D4N-7C2HR	D4N-7D2HR
		M20	D4N-8A2HR	D4N-8B2HR	D4N-8C2HR	D4N-8D2HR
		M12 connector	D4N-9A2HR	D4N-9B2HR	---	---
Plunger 	1-conduit	Pg13.5	D4N-1A31R	D4N-1B31R	D4N-1C31R	D4N-1D31R
		G1/2	D4N-2A31R	D4N-2B31R	D4N-2C31R	D4N-2D31R
		1/2-14NPT	D4N-3A31R	D4N-3B31R	D4N-3C31R	D4N-3D31R
		M20	D4N-4A31R	D4N-4B31R	D4N-4C31R	D4N-4D31R
		M12 connector	D4N-9A31R	D4N-9B31R	---	---
	2-conduit	Pg13.5	D4N-5A31R	D4N-5B31R	D4N-5C31R	D4N-5D31R
		G1/2	D4N-6A31R	D4N-6B31R	D4N-6C31R	D4N-6D31R
		1/2-14NPT (See note 2.)	D4N-7A31R	D4N-7B31R	D4N-7C31R	D4N-7D31R
		M20	D4N-8A31R	D4N-8B31R	D4N-8C31R	D4N-8D31R
		M12 connector	D4N-9A31R	D4N-9B31R	---	---
Roller plunger 	1-conduit	Pg13.5	D4N-1A32R	D4N-1B32R	D4N-1C32R	D4N-1D32R
		G1/2	D4N-2A32R	D4N-2B32R	D4N-2C32R	D4N-2D32R
		1/2-14NPT	D4N-3A32R	D4N-3B32R	D4N-3C32R	D4N-3D32R
		M20	D4N-4A32R	D4N-4B32R	D4N-4C32R	D4N-4D32R
		M12 connector	D4N-9A32R	D4N-9B32R	---	---
	2-conduit	Pg13.5	D4N-5A32R	D4N-5B32R	D4N-5C32R	D4N-5D32R
		G1/2	D4N-6A32R	D4N-6B32R	D4N-6C32R	D4N-6D32R
		1/2-14NPT (See note 2.)	D4N-7A32R	D4N-7B32R	D4N-7C32R	D4N-7D32R
		M20	D4N-8A32R	D4N-8B32R	D4N-8C32R	D4N-8D32R
		M12 connector	D4N-9A32R	D4N-9B32R	---	---

Safety Limit Switches  
D4N-□R

Actuator	Conduit size		Built-in switch mechanism			
			1NC/1NO (Slow-action)	2NC (Slow-action)	2NC/1NO (Slow-action)	3NC (Slow-action)
One-way roller arm lever (horizontal) 	1-conduit	Pg13.5	D4N-1A62R	D4N-1B62R	D4N-1C62R	D4N-1D62R
		G1/2	D4N-2A62R	D4N-2B62R	D4N-2C62R	D4N-2D62R
		1/2-14NPT	D4N-3A62R	D4N-3B62R	D4N-3C62R	D4N-3D62R
		M20	D4N-4A62R	D4N-4B62R	D4N-4C62R	D4N-4D62R
		M12 connector	D4N-9A62R	D4N-9B62R	---	---
	2-conduit	Pg13.5	D4N-5A62R	D4N-5B62R	D4N-5C62R	D4N-5D62R
		G1/2	D4N-6A62R	D4N-6B62R	D4N-6C62R	D4N-6D62R
		1/2-14NPT (See note 2.)	D4N-7A62R	D4N-7B62R	D4N-7C62R	D4N-7D62R
		M20	D4N-8A62R	D4N-8B62R	D4N-8C62R	D4N-8D62R
		M12 connector	D4N-9A62R	D4N-9B62R	---	---
One-way roller arm lever (vertical) 	1-conduit	Pg13.5	D4N-1A72R	D4N-1B72R	D4N-1C72R	D4N-1D72R
		G1/2	D4N-2A72R	D4N-2B72R	D4N-2C72R	D4N-2D72R
		1/2-14NPT	D4N-3A72R	D4N-3B72R	D4N-3C72R	D4N-3D72R
		M20	D4N-4A72R	D4N-4B72R	D4N-4C72R	D4N-4D72R
		M12 connector	D4N-9A72R	D4N-9B72R	---	---
	2-conduit	Pg13.5	D4N-5A72R	D4N-5B72R	D4N-5C72R	D4N-5D72R
		G1/2	D4N-6A72R	D4N-6B72R	D4N-6C72R	D4N-6D72R
		1/2-14NPT (See note 2.)	D4N-7A72R	D4N-7B72R	D4N-7C72R	D4N-7D72R
		M20	D4N-8A72R	D4N-8B72R	D4N-8C72R	D4N-8D72R
		M12 connector	D4N-9A72R	D4N-9B72R	---	---

- Note:** 1. It is recommended that M20 be used for Switches to be exported to Europe and 1/2-14NPT be used for Switches to be exported to North American countries.  
 2. The 1/2-14NPT 2-conduit models include an M20-to-1/2-14NPT changing adaptor.

## Specifications

### Standards and EC Directives

- Conforms to the following EC Directives:  
 Machinery Directive  
 Low Voltage Directive  
 EN50047  
 EN1088  
 GS-ET-15

### Approved Standards

Agency	Standard	File No.
TÜV Product Service	EN60947-5-1 (approved direct opening)	(See note 1.)
UL (See note 2.)	UL508, CSA C22.2 No.14	E76675
CCC (CQC) (See note 3.)	GB14048.5	2004010305105973

- Note:** 1. Consult your OMRON representative for details.  
 2. Approval for CSA C22.2 No. 14 is authorized by the UL mark.  
 3. Ask your OMRON representative for information on approved models.

### Approved Standard Ratings

#### TÜV (EN60947-5-1), CCC (GB14048.5)

Item	Utilization category	AC-15	DC-13
Rated operating current ( $I_n$ )		3 A	0.27 A
Rated operating voltage ( $U_n$ )		240 V	250 V

**Note:** Use a 10-A fuse type gI or gG that conforms to IEC269 as a short-circuit protection device. This fuse is not built into the Switch.

#### UL/CSA (UL508, CSA C22.2 No. 14)

##### A300

Rated voltage	Carry current	Current		Volt-amperes	
		Make	Break	Make	Break
120 VAC	10 A	60 A	6 A	7,200 VA	720 VA
240 VAC		30 A	3 A		

##### Q300

Rated voltage	Carry current	Current		Volt-amperes	
		Make	Break	Make	Break
125 VDC	2.5 A	0.55 A	0.55 A	69 VA	69 VA
250 VDC		0.27 A	0.27 A		

## ■ Characteristics

<b>Degree of protection (See note 3.)</b>		IP67 (EN60947-5-1)
<b>Durability (See note 4.)</b>	<b>Mechanical</b>	1,000,000 operations min.
	<b>Electrical</b>	500,000 operations min. for a resistive load of 3 A at 250 VAC (See note 5.) 300,000 operations min. for a resistive load of 10 A at 250 VAC
<b>Operating speed</b>		1 to 500 mm/s (D4N-1A20R)
<b>Operating frequency</b>		30 operations/minute max.
<b>Contact resistance</b>		25 mΩ max.
<b>Minimum applicable load (See note 6.)</b>		Resistive load of 1 mA at 5 VDC (N-level reference value)
<b>Rated insulation voltage (U<sub>i</sub>)</b>		300 V
<b>Protection against electric shock</b>		Class II (double insulation)
<b>Pollution degree (operating environment)</b>		Level 3 (EN60947-5-1)
<b>Impulse withstand voltage (EN60947-5-1)</b>		Between terminals of the same polarity: 2.5 kV
		Between terminals of different polarities: 4 kV
		Between other terminals and uncharged metallic parts: 6 kV
<b>Insulation resistance</b>		100 MΩ min.
<b>Contact gap</b>		Snap-action: 2 x 0.5 mm min Slow-action: 2 x 2 mm min
<b>Vibration resistance</b>	<b>Malfunction</b>	10 to 55 Hz, 0.75-mm single amplitude
<b>Shock resistance</b>	<b>Destruction</b>	1,000 m/s <sup>2</sup>
	<b>Malfunction</b>	300 m/s <sup>2</sup>
<b>Conditional short-circuit current</b>		100 A (EN60947-5-1)
<b>Rated open thermal current (I<sub>th</sub>)</b>		10 A (EN60947-5-1)
<b>Ambient temperature</b>		Operating: -30°C to 70°C with no icing
<b>Ambient humidity</b>		Operating: 95% max.
<b>Weight</b>		Approx. 92 g (D4N-1A20R)

- Note:**
- The above values are initial values.
  - Once a contact has been used to switch a standard load, it cannot be used for a load of a smaller capacity. Doing so may result in roughening of the contact surface and contact reliability may be lost.
  - The degree of protection is tested using the method specified by the standard (EN60947-5-1). Confirm that sealing properties are sufficient for the operating conditions and environment beforehand. Although the switch box is protected from dust or water penetration, do not use the D4N-□R in places where foreign material such as dust, dirt, oil, water, or chemicals may penetrate through the head. Otherwise, premature wear, Switch damage or malfunctioning may occur.
  - The durability is for an ambient temperature of 5°C to 35°C and an ambient humidity of 40% to 70%. For more details, consult your OMRON representative.
  - If the ambient temperature is greater than 35°C, do not pass the 3-A, 250-VAC load through more than 2 circuits.
  - This value will vary with the switching frequency, environment, and reliability level. Confirm that correct operation is possible with the actual load beforehand.

# Connections

## Contact Form

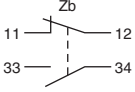
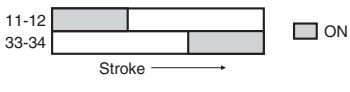
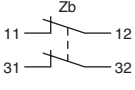
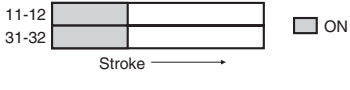
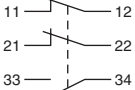
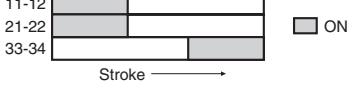
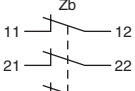
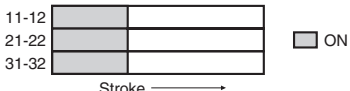
Model	Contact	Contact form	Operating pattern	Remarks
D4N-□A□R	1NC/1NO			Only NC contacts 11-12 have an approved direct opening mechanism. (→) The terminals 11-12 and 33-34 can be used as unlike poles.
D4N-□B□R	2NC			Only NC contacts 11-12 and 31-32 have an approved direct opening mechanism. (→) The terminals 11-12 and 31-32 can be used as unlike poles.
D4N-□C□R	2NC/1NO			Only NC contacts 11-12 and 21-22 have an approved direct opening mechanism. (→) The terminals 11-12, 21-22, and 33-34 can be used as unlike poles.
D4N-□D□R	3NC			Only NC contacts 11-12, 21-22, and 31-32 have an approved direct opening mechanism. (→) The terminals 11-12, 21-22, and 31-32 can be used as unlike poles.

Safety Limit Switches D4N-□R

## Operation

### Direct Opening Mechanism

#### 1NC/1NO Contact (Slow-action)

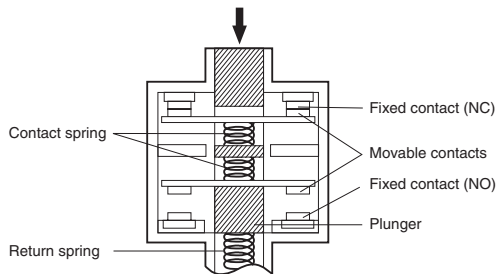

Only the NC contact side has a direct opening mechanism. When contact welding occurs, the contacts are separated from each other by the plunger being pushed in. (Conforms to EN60947-5-1 Direct Opening Operation.)

#### 2NC Contact (Slow-action)

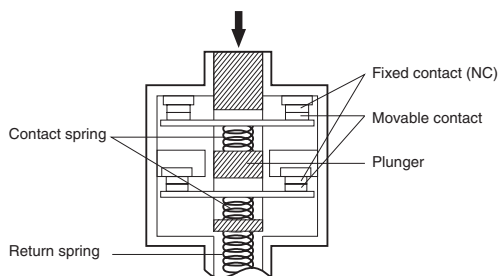

Both NC contacts have a direct opening mechanism. When contact welding occurs, the contacts are separated from each other by the plunger being pushed in. (Conforms to EN60947-5-1 Direct Opening Operation.)

# Nomenclature

## ■ Structure

### Safety-oriented Lever Setting

Grooves which engage the lever are cut in the lever and rotary shaft to prevent the lever from slipping against the rotary shaft. The actuator locks (self-holding) when it moves to the lock position.

### Reset Head (Blue)

The direction of the reset head can be adjusted to any of the four directions.

### Built-in Switch

The built-in switch has a direct opening mechanism that forcibly separates the NC contact even when there is contact deposit.

### Cover

The cover, with a hinge on its lower part, can be opened by removing the screw of the cover, which ensures ease of maintenance and wiring.

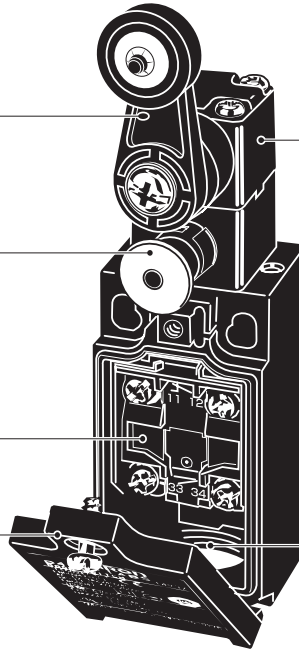

### Head

With roller lever models, the direction of the switch head can be adjusted to any of the four directions by loosening the roller lever switch screws at the four corners of the head.

### Conduit

A wide variety of conduits is available.

Size	Box	1-conduit model	2-conduit model
Pg13.5		Yes	Yes
G1/2		Yes	Yes
1/2-14NPT		Yes	Yes
M20		Yes	Yes
M12 connector		Yes	---

**Note:** M12 connector types are not available for Switches with three contacts.

Safety Limit  
Switches

D4N-□R

# Dimensions

## Switches

Note: All units are in millimeters unless otherwise indicated.

### 1-conduit Models

#### Roller Lever (Resin Lever, Resin Roller)

D4N-1□20R D4N-2□20R  
 D4N-3□20R D4N-4□20R  
 D4N-9□20R (See note 3.)

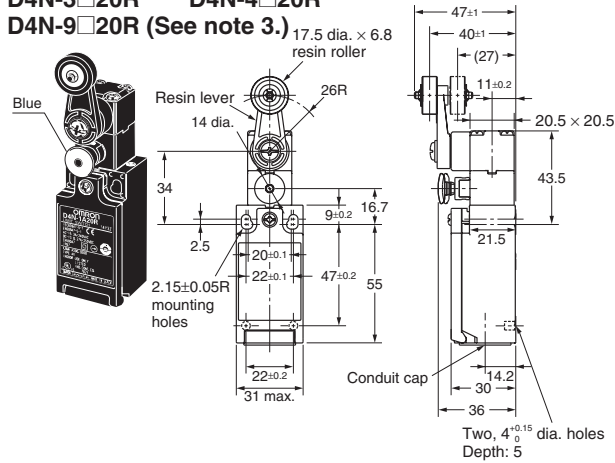

#### Adjustable Roller Lever, Form Lock (with Metal Lever, Resin Roller)

D4N-1□2GR D4N-2□2GR  
 D4N-3□2GR D4N-4□2GR  
 D4N-9□2GR (See note 3.)

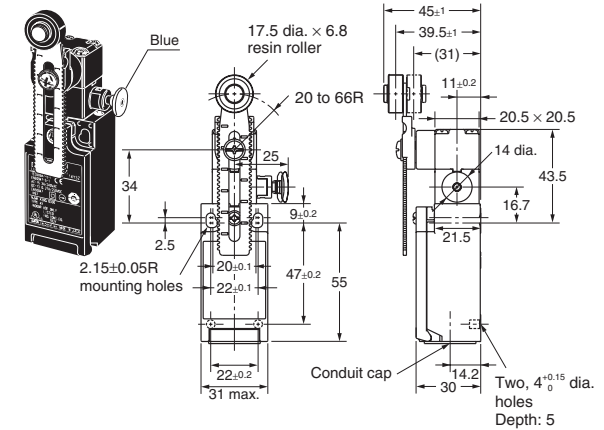

#### Adjustable Roller Lever, Form Lock (with Metal Lever, Rubber Roller)

D4N-1□2HR D4N-2□2HR  
 D4N-3□2HR D4N-4□2HR  
 D4N-9□2HR (See note 3.)

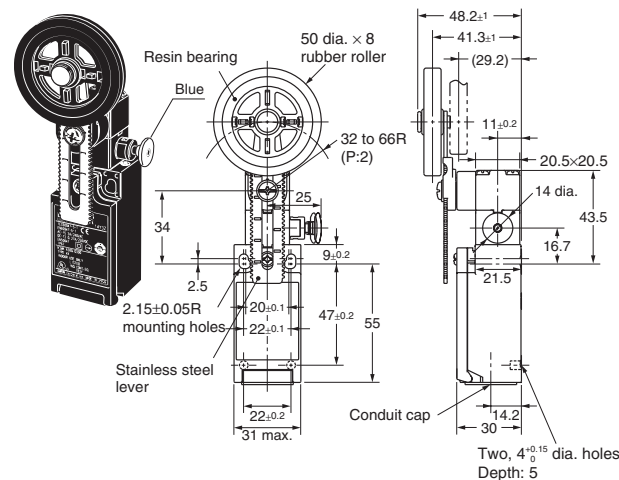

Note: 1. Unless otherwise specified, a tolerance of  $\pm 0.4$  mm applies to all dimensions.

2. Variation occurs in the simultaneity of contact opening/closing operations of 2NC, 2NC/1NO, and 3NC contacts. Check contact operation.

3. Refer to the following diagram for details on 1-conduit M12 connectors.

### 1-conduit M12 Connectors

D4N-9□□□R

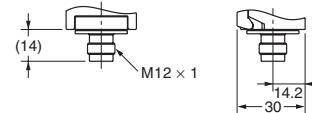

Note: 1. Variation occurs in the simultaneity of contact opening/closing operations of 2NC, 2NC/1NO, and 3NC contacts. Check contact operation.

2. The operating characteristics of these Switches were measured with the roller lever set at 32 mm.

3. These PT values are possible when the NC contacts are open (OFF).

4. These PT values are reference values possible when the NO contacts are closed (ON). (1NC/1NO models only)

5. Reference value.

6. Load and stroke values for the direct opening mechanism. For safe use, always make sure that the minimum values or greater are provided.

Model	D4N-□□20R	D4N-□□2GR (See note 2.)	D4N-□□2HR
LF max.	6.4 N	5.6 N	5.4 N
LT max.	55°	55°	55°
PT 1 (See note 3.)	18 to 27°	18 to 27°	18 to 27°
(PT 2) (See note 4.)	(44°)	(44°)	(44°)
(TT) (See note 5.)	80°	80°	80°
DOF min. (See note 6.)	20 N	20 N	20 N
DOT min. (See note 6.)	50°	50°	50°

1-conduit Models

Plunger

D4N-1□31R D4N-2□31R  
 D4N-3□31R D4N-4□31R  
 D4N-9□31R (See note 3.)

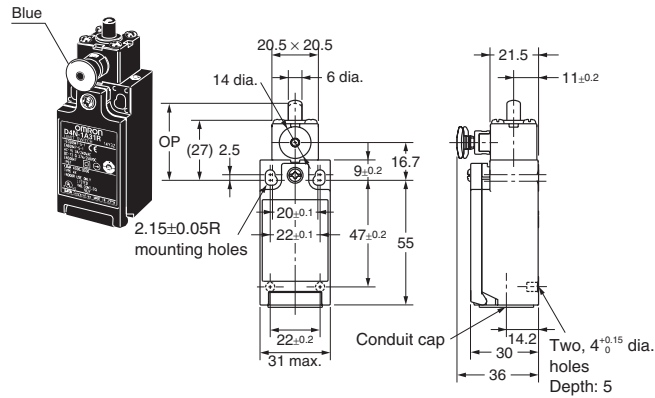

Roller Plunger

D4N-1□32R D4N-2□32R  
 D4N-3□32R D4N-4□32R  
 D4N-9□32R (See note 3.)

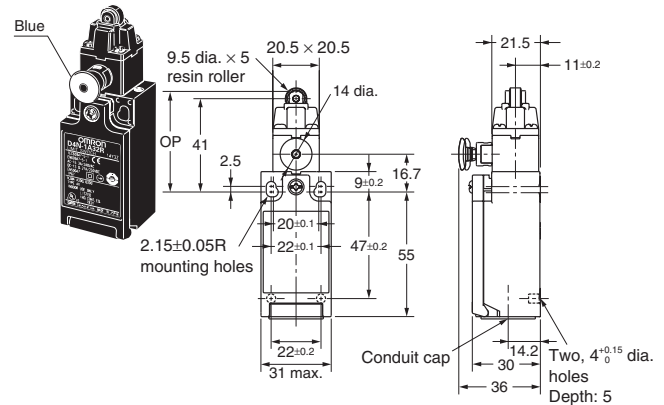

One-way Roller Arm Lever (Horizontal)

D4N-1□62R D4N-2□62R  
 D4N-3□62R D4N-4□62R  
 D4N-9□62R (See note 3.)

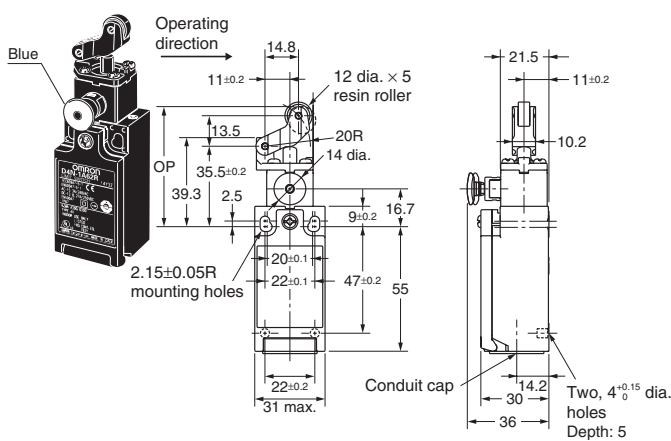

One-way Roller Arm Lever (Vertical)

D4N-1□72R D4N-2□72R  
 D4N-3□72R D4N-4□72R  
 D4N-9□72R (See note 3.)

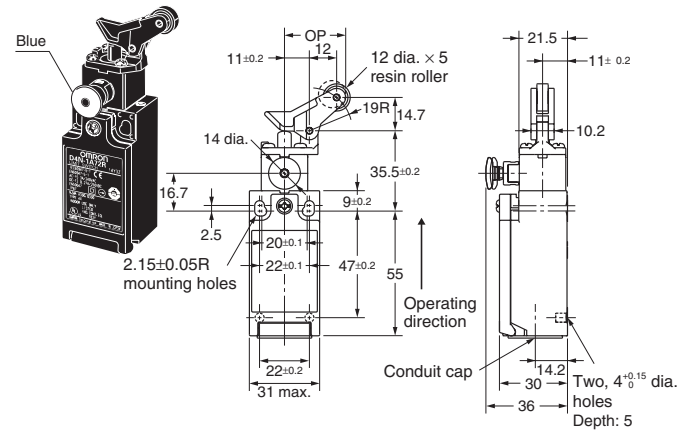

Note: 1. Unless otherwise specified, a tolerance of ±0.4 mm applies to all dimensions.

2. Variation occurs in the simultaneity of contact opening/closing operations of 2NC and 3NC contacts. Check contact operation.

3. Refer to page B-61 for details on 1-conduit M12 connectors.

Model	D4N-□□31R	D4N-□□32R	D4N-□□62R	D4N-□□72R
LF max.	10.8 N	10.8N	7.5 N	7.9 N
LT max.	4.5 mm	4.5 mm	7 mm	7 mm
PT 1 (See note 2.)	2 mm	2 mm	4 mm	4 mm
(PT 2) (See note 3.)	(2.9 mm)	(2.9 mm)	(5.2 mm)	(4.3 mm)
OP	34 ±0.5 mm	44.4 ±0.8 mm	53 ±0.8 mm	27 ±0.8 mm
(TT) (See note 4.)	(6 mm)	(6 mm)	(9 mm)	(9 mm)
DOF min. (See note 5.)	20 N	20 N	20 N	20 N
DOT min. (See note 5.)	3.2 mm	3.2 mm	5.8 mm	4.8 mm

- Note: 1. Variation occurs in the simultaneity of contact opening/closing operations of 2NC, 2NC/1NO, and 3NC contacts. Check contact operation.
2. These PT values are possible when the NC contacts are open (OFF).
3. These PT values are reference values possible when the NO contacts are closed (ON). (1NC/1NO models only)
4. Reference value.
5. Load and stroke values for the direct opening mechanism. For safe use, always make sure that the minimum values or greater are provided.

Safety Limit Switches D4N-□R



## 2-conduits Models

### Roller Lever (Resin Lever, Resin Roller)

D4N-5□20R D4N-6□20R  
D4N-7□20R D4N-8□20R

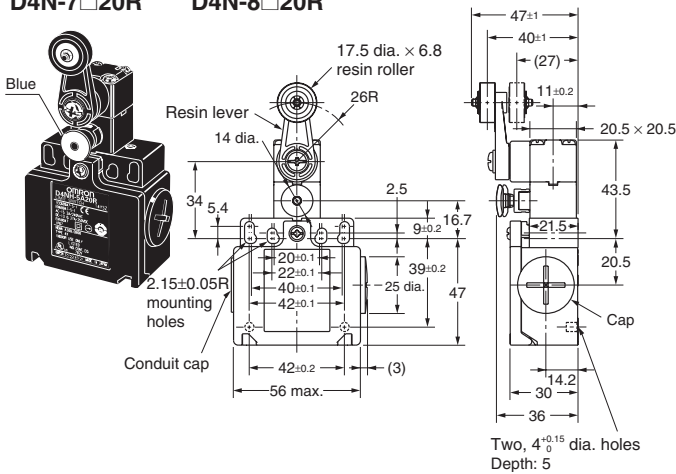

### Adjustable Roller Lever, Form Lock (with Metal Lever, Resin Roller)

D4N-5□2GR D4N-6□2GR  
D4N-7□2GR D4N-8□2GR

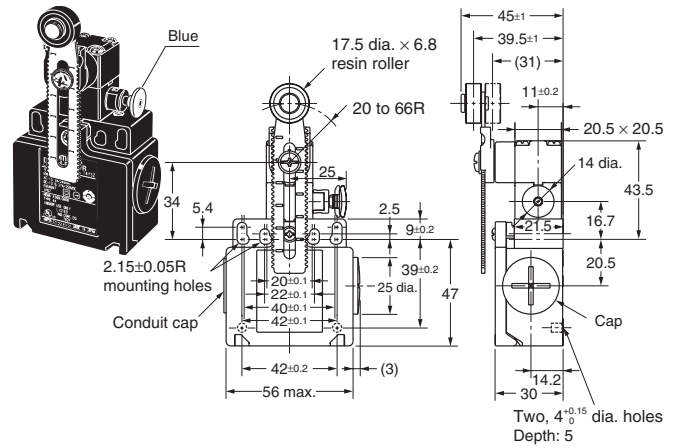

### Adjustable Roller Lever, Form Lock (with Metal Lever, Rubber Roller)

D4N-5□2HR D4N-6□2HR  
D4N-7□2HR D4N-8□2HR

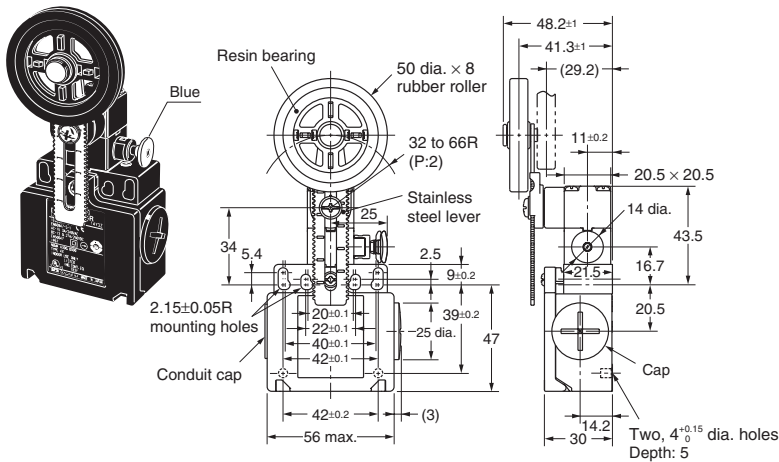

**Note:** 1. Unless otherwise specified, a tolerance of  $\pm 0.4$  mm applies to all dimensions.

2. Variation occurs in the simultaneity of contact opening/closing operations of 2NC and 3NC contacts. Check contact operation.

Model	D4N-□□20R	D4N-□□2GR	D4N-□□2HR
LF max.	6.4 N	5.6 N	5.4 N
LT max.	55°	55°	55°
PT 1 (See note 2.)	18° to 27°	18° to 27°	18° to 27°
(PT 2) (See note 3.)	(44°)	(44°)	(44°)
(TT) (See note 4.)	80°	80°	80°
DOF min. (See note 5.)	20 N	20 N	20 N
DOT min. (See note 5.)	50°	50°	50°

- Note:** 1. Variation occurs in the simultaneity of contact opening/closing operations of 2NC, 2NC/1NO, and 3NC contacts. Check contact operation.
2. These PT values are possible when the NC contacts are open (OFF).
3. These PT values are reference values possible when the NO contacts are closed (ON). (1NC/1NO models only)
4. Reference value.
5. Load and stroke values for the direct opening mechanism. For safe use, always make sure that the minimum values or greater are provided.

## 2-conduits Models

### Plunger

D4N-5□31R  
D4N-6□31R  
D4N-7□31R  
D4N-8□31R

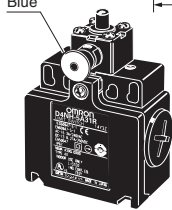
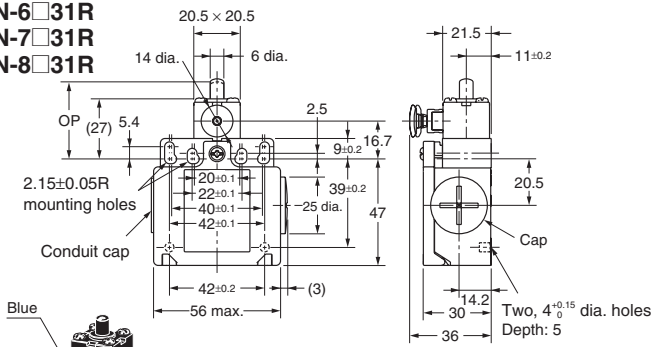

### Roller Plunger

D4N-5□32R    D4N-6□32R  
D4N-7□32R    D4N-8□32R

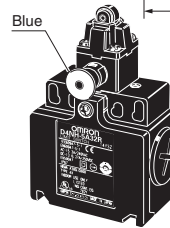
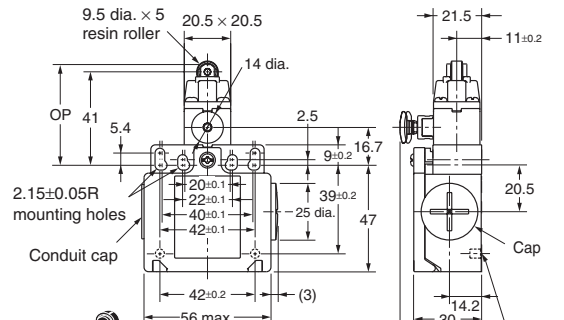

### One-way Roller Arm Lever (Horizontal)

D4N-5□62R    D4N-6□62R  
D4N-7□62R    D4N-8□62R

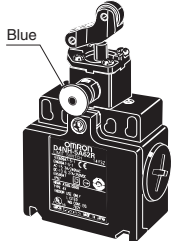
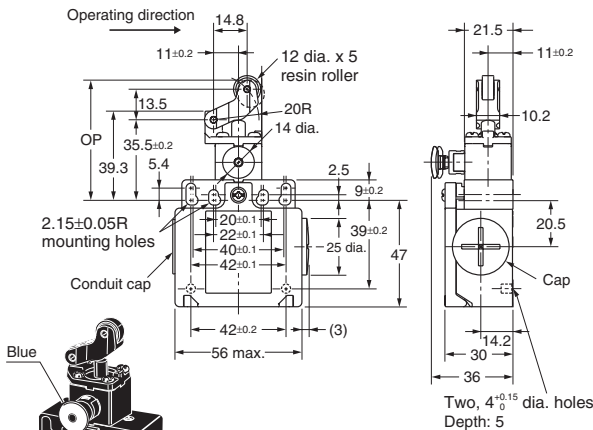

### One-way Roller Arm Lever (Vertical)

D4N-5□72R    D4N-6□72R  
D4N-7□72R    D4N-8□72R

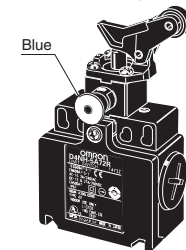
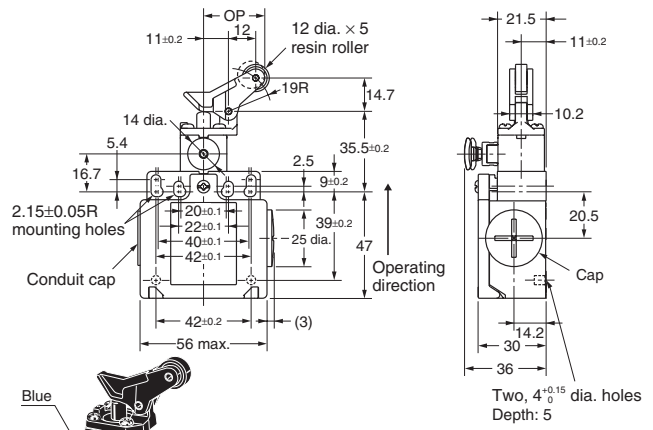

**Note:** 1. Unless otherwise specified, a tolerance of  $\pm 0.4$  mm applies to all dimensions.

2. Variation occurs in the simultaneity of contact opening/closing operations of 2NC and 3NC contacts. Check contact operation.

Model	D4N-□□31R	D4N-□□32R	D4N-□□62R	D4N-□□72R
LF max.	10.8 N	10.8 N	7.5 N	7.9 N
LT max.	4.5 mm	4.5 mm	7 mm	7 mm
PT 1 max. (See note 2.)	2 mm	2 mm	4 mm	4 mm
(PT 2) (See note 3.)	(2.9 mm)	(2.9 mm)	(5.2 mm)	(4.3 mm)
OP	34 $\pm$ 0.5 mm	44.4 $\pm$ 0.8 mm	53 $\pm$ 0.8 mm	27 $\pm$ 0.8 mm
(TT) (See note 4.)	(6 mm)	(6 mm)	(9 mm)	(9 mm)
DOF min. (See note 5.)	20 N	20 N	20 N	20 N
DOT min. (See note 5.)	3.2 mm	3.2 mm	5.8 mm	4.8 mm

**Note:** 1. Variation occurs in the simultaneity of contact opening/closing operations of 2NC, 2NC/1NO, and 3NC contacts. Check contact operation.

2. These PT values are possible when the NC contacts are open (OFF).

3. These PT values are reference values possible when the NO contacts are closed (ON). (1NC/1NO models only)

4. Reference value.

5. Load and stroke values for the direct opening mechanism. For safe use, always make sure that the minimum values or greater are provided.

Safety Limit Switches

D4N-□R

## Levers

Refer to the following diagrams for the angles and positions of the dogs.

**Roller Lever  
(D4N-□□20R)**

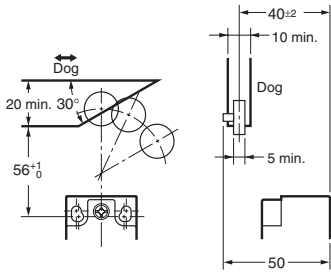

**Adjustable Roller Lever, Form Lock  
(with Metal Lever, Resin Roller)  
(D4N-□□2GR)**

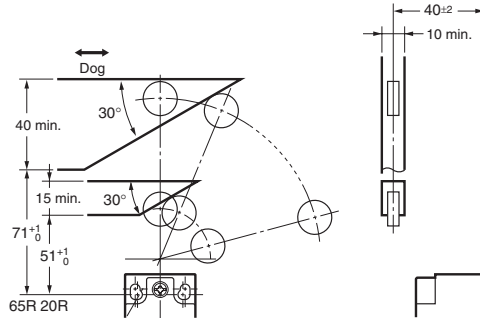

**Adjustable Roller Lever, Form Lock  
(with Metal Lever, Rubber Roller)  
(D4N-□□2HR)**

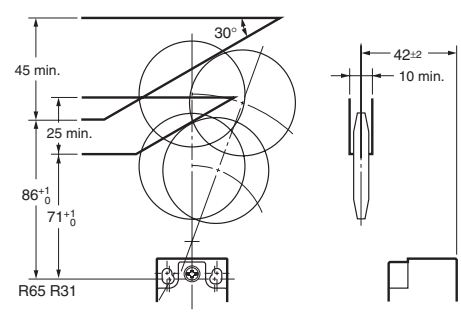

**Sealed Plunger  
(D4N-□□31R)**

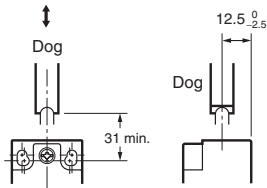

**Roller Plunger  
(D4N-□□32R)**

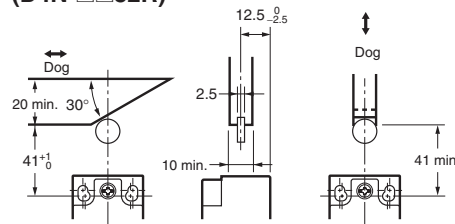

**One-way Roller Arm Lever  
(Horizontal)  
(D4N-□□62R)**

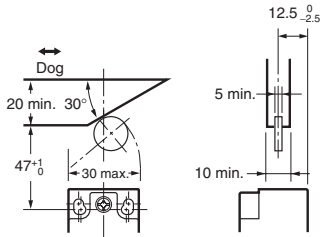

**One-way Roller Arm Lever  
(Vertical)  
(D4N-□□72R)**

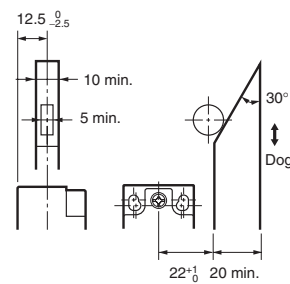

**Note:** Unless otherwise specified, a tolerance of  $\pm 0.4$  mm applies to all dimensions.

# Safety Precautions

Refer to the "Precautions for All Switches" on page I-2 and "Precautions for All Safety Limit Switches" on page B-2.

## ⚠ CAUTION

Do not use metal connectors or metal conduits. If the Switch is made of resin, damage at the conduit section may cause electric shock.



## ■ Precautions for Safe Use

- Do not drop the Switch. Doing so may result in the Switch not performing to its full capacity.
- Do not attempt to disassemble or modify the Switch. Doing so may cause the Switch to malfunction.
- Do not use the Switch where explosive gas or flammable gas may be present.
- Install the Switch in a location away from close body contact. Not doing so may result in malfunction.
- Do not use the Switch submerged in oil or water, or in locations continuously subject to splashes of oil or water. Doing so may result in oil or water entering the Switch interior. (The IP67 degree of protection specification for the Switch refers to water penetration while the Switch is submerged in water for a specified period of time.)
- Protect the head from foreign material. Subjecting the head to foreign material may result in premature wear or damage to the Switch. Although the switch body is protected from penetration by dust or water, the head is not protected from penetration by minute particles or water.
- Turn the power OFF before wiring. Doing so may result in electric shock.
- Install the cover after wiring. Not doing so may result in electric shock.
- Connect a fuse to the Switch in series to protect the Switch from short-circuit damage. Use a fuse with a breaking current 1.5 to 2 times larger than the rated current. To conform to EN ratings, use an IEC60269-compliant 10-A fuse type gI or gG.
- Do not switch circuits for two or more standard loads (250 VAC, 3 A) at the same time. Doing so may adversely affect insulation performance.
- The durability of the Switch is greatly affected by operating conditions. Evaluate the Switch under actual working conditions, before permanent installation and use within a number of switching operations that will not adversely affect the Switch's performance.
- Be sure to indicate in the machine manufacturer's instruction manual that the user must not attempt to repair or maintain the Switch and must contact the machine manufacturer for any repairs or maintenance.
- If the Switch is to be used in an emergency stop circuit or in a safety circuit for preventing accidents resulting in injuries or deaths, use a model that has an NC contact equipped with a direct opening mechanism and make sure that the Switch operates in the direct opening mode. Furthermore, secure the Switch with screws or equivalent parts that are tightened in a single direction so that the Switch cannot be easily removed. Then provide a protection cover for the Switch and post a warning label near the Switch.
- Make sure that the actuator is pushed into the lock position. Not doing so may result in the actuator becoming unlocked, causing an accident.
- Always reset the Switch manually. Not doing so may result in damage to the reset function.
- When the Switch locks due to a fault in the system, be sure to reset the Switch manually before resupplying power after confirming the safety of the system.
- Check the Switches before use and inspect regularly, replacing them when necessary. If a Switch is kept pressed for an extended period of time, the components may deteriorate quickly, and the Switch may not release.
- When using the Switch as a safety component, be sure to check the system design for both operational and circuit safety.

## ■ Precautions for Correct Use

### Environment

- The Switch is intended for indoor use only.
- Do not use the Switch outdoors. Doing so may cause the Switch to malfunction.
- Do not use the Switch where corrosive gases (e.g., H<sub>2</sub>S, SO<sub>2</sub>, NH<sub>3</sub>, HNO<sub>3</sub>, Cl<sub>2</sub>) are present or in locations subject to high temperature and humidity. Doing so may result in damage to the Switch caused by contact failure or corrosion.
- Do not use the Switches in the following locations.
  - Locations subject to severe temperature changes
  - Locations subject to high temperatures or condensation
  - Locations subject to severe vibration
  - Locations where the interior of the Protective Door may come into direct contact with cutting chips, metal filings, oil, or chemicals
  - Locations where the Switch may come into contact with thinner or detergents

### Mounting Method

#### Mounting Screw Tightening Torque

Tighten each of the screws to the specified torque. Loose screws may result in malfunction of the Switch within a short time.

1	Terminal screw	0.6 to 0.8 N·m
2	Cover clamping screw	0.5 to 0.7 N·m
3	Head clamping screw	0.5 to 0.6 N·m
4	Lever clamping screw	1.6 to 1.8 N·m
5	Body clamping screw	0.5 to 0.7 N·m
6	Conduit mounting connection, M12 adaptor	1.8 to 2.2 N·m (except 1/2-14NPT) 1.4 to 1.8 N·m (1/2-14NPT)
7	Cap screw	1.3 to 1.7 N·m

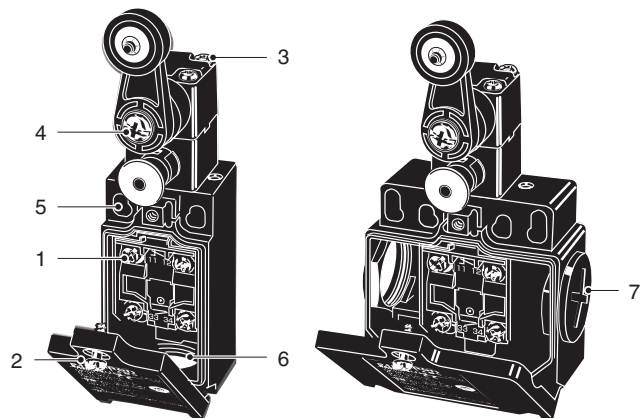

### Switch Mounting

- Mount the Switch using M4 screws and washers and tighten the screws to the specified torque.
- For safety, use screws that cannot be easily removed, or use an equivalent measure to ensure that the Switch is secure.
- Secure the Switch with two M4 bolts and washers. Provide studs with a diameter of  $4_{-0.05}^{+0.15}$  and a height of 4.8 mm max. at two places, inserting into the holes at the bottom of the Switch as shown below so that the Switch is firmly fixed at four points.

**Switch Mounting Holes**  
**One-conduit Type**

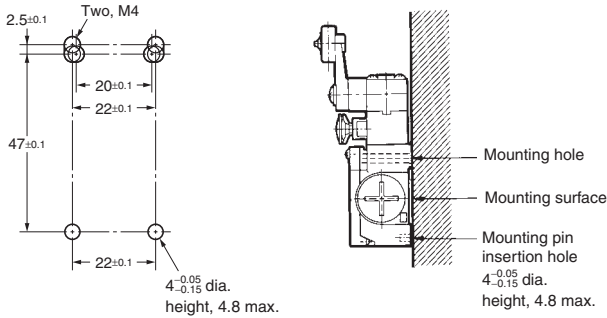

**Two-conduit Type**

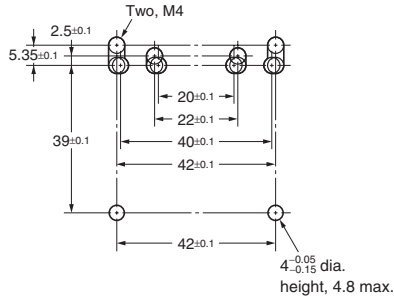

**Changing the Head Direction**

By removing the four screws of the head, the mounting direction of the head can be changed. The head can be mounted in four directions. Be sure that no foreign material will enter the head during a change in direction.

**Wiring**

- When connecting to the terminals via insulating tube and M3.5 crimp terminals, arrange the crimp terminals as shown below so that they do not rise up onto the case or the cover. Applicable lead wire size: AWG20 to AWG18 (0.5 to 0.75 mm<sup>2</sup>). Use lead wires of an appropriate length, as shown below. Not doing so may result in excess length causing the cover to rise and not fit properly.

**One-conduit Type (3 Poles)**

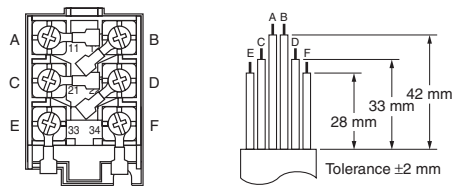

**Two-conduit Type (3 Poles)**

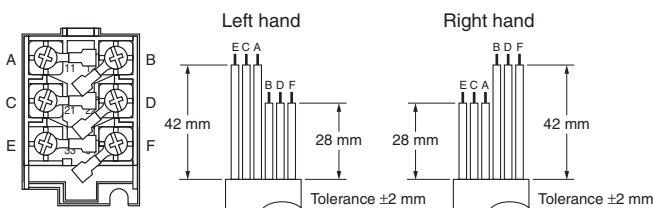

- Do not push crimp terminals into gaps in the case interior. Doing so may cause damage or deformation of the case.
- Use crimp terminals not more than 0.5 mm in thickness. Otherwise, they will interfere with other components inside the case. The crimp terminals shown below are not more than 0.5 mm thick.

Manufacture	Type	Wire size
J.S.T.	FV0.5-3.7 (F type) V0.5-3.7 (straight type)	AWG20 (0.5 mm <sup>2</sup> )

J.S.T is a Japanese manufacturer.

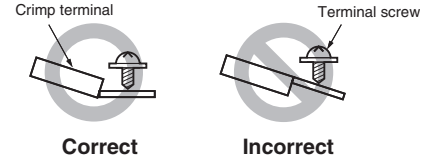
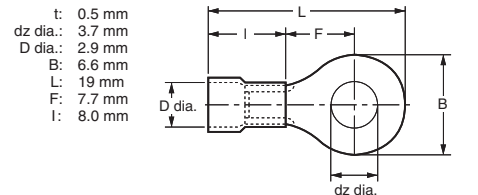

**Contact Arrangement**

- The following diagrams show the contact arrangements used for screw terminal types and connector types.

**Screw Terminal Type**

D4N-□D□□R (3NC)

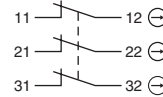

D4N-□C□□R (2NC/1NO)

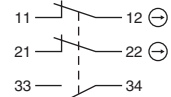

D4N-□B□□R (2NC)

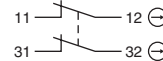

D4N-□A□□R (1NC/1NO)

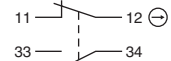

**Connector Type**

D4N-9B□□R (2NC)

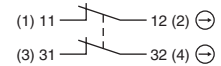

D4N-9A□□R (1NC/1NO)

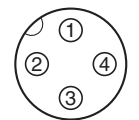

Pin No. (Terminal No.)

- Applicable socket: XS2F (OMRON).
- Refer to the *Connector Catalog* for details on socket pin numbers and lead wire colors.

**Socket Tightening (Connector Type)**

- Turn the socket connector screws by hand and tighten until no space remains between the socket and the plug.
- Make sure that the socket connector is tightened securely. Otherwise, the rated degree of protection (IP67) may not be maintained and vibration may loosen the socket connector.

**Conduit Opening**

- Connect a recommended connector to the opening of the conduit and tighten the connector to the specified torque. The case may be damaged if an excessive tightening torque is applied.
- When using 1/2-14NPT, wind sealing tape around the joint between the connector and conduit opening so that the enclosure will conform to IP67.
- Use a cable with a suitable diameter for the connector.
- Attach and tighten a conduit cap to the unused conduit opening when wiring. Tighten the conduit cap to the specified torque. The conduit cap is provided with the Switch (2-conduit types).

## Recommended Connectors

Use connectors with screws not exceeding 9 mm, otherwise the screws will protrude into the case interior, interfering with other components in the case. The connectors listed in the following table have connectors with thread sections not exceeding 9 mm. Use the recommended connectors to ensure conformance to IP67.

Size	Manufacturer	Model	Applicable cable diameter
G1/2	LAPP	ST-PF1/2 5380-1002	6.0 to 12.0 mm
Pg13.5	LAPP	S-13.5 5301-5030	6.0 to 12.0 mm
M20	LAPP	ST-M20 × 1.5 5311-1020	7.0 to 13.0 mm
1/2-14NPT	LAPP	ST-NPT1/2 5301-6030	6.0 to 12.0 mm
M12	LAPP	ST-M12 × 1.5 5301-1000	3.5 to 7.0 mm

Use LAPP connectors together with seal packing (JPK-16, GP-13.5, GPM20, or GPM12), and tighten to the specified tightening torque. Seal packing is sold separately.

LAPP is a German manufacturer.

Before using an M12 type, attaching the provided changing adaptor to the Switch and then connect the recommended connector.

Before using a 2-conduit 1/2-14NPT type, attach the provided changing adaptor to the Switch and then connect the recommended connector.

## Storage

Do not store the Switch in locations where corrosive gases (e.g., H<sub>2</sub>S, SO<sub>2</sub>, NH<sub>3</sub>, HNO<sub>3</sub>, Cl<sub>2</sub>) or dust is present, or in locations subject to high temperatures and humidity.

## Others

- Do not allow the load current to exceed the rated value.
- Confirm that the seal rubber has no defects before use.  
If the seal rubber is displaced or raised, or has foreign particles adhered to it, the sealing capability of the seal rubber will be adversely affected.
- Use the correct cover mounting screws only, or the sealing capability of the seal rubber will deteriorate.
- Inspect the Switch regularly.
- With rubber roller lever models, the rubber roller may turn white over time, but this will not affect the quality of operation.
- Use the following recommended countermeasures to prevent telegraphing when using adjustable or long levers.
  1. Make the rear edge of the dog smooth with an angle of 15° to 30° or make it in the shape of a quadratic curve.
  2. Design the circuit so that no error signal will be generated.
  3. Use or set a Switch that is operated in one direction only.

# Production Discontinuation

Following the release of the D4N-R, production of the D4D-R will be discontinued.

## Date of Production Discontinuation

Production of the D4D-R Series will be discontinued as of the end of March 2006.

## Product Replacement

### 1. Dimensions

The D4D-R and D4N-R use the same mounting method, and mounting hole. The multi-contact structure and the extra 4 mm in length, however, are different.

### 2. Terminal Numbers

For the 2-contact model, the terminals 21, 22, 23, and 24 on the D4D-R are 31, 32, 33, and 34 on the D4N-R.

### 3. Recommended Terminals

If the recommended terminals are not used, the Switch may not be compatible. Make sure that the Switch is compatible with the terminals.

## Comparison of the D4D-R and Substitute Products

Model	D4N-R
Switch color	Very similar
Dimensions	Very similar
Wiring/connection	Significantly different
Mounting method	Completely compatible
Ratings/performance	Very similar
Operating characteristics	Very similar
Operating method	Completely compatible

## Dimensions (Unit: mm)

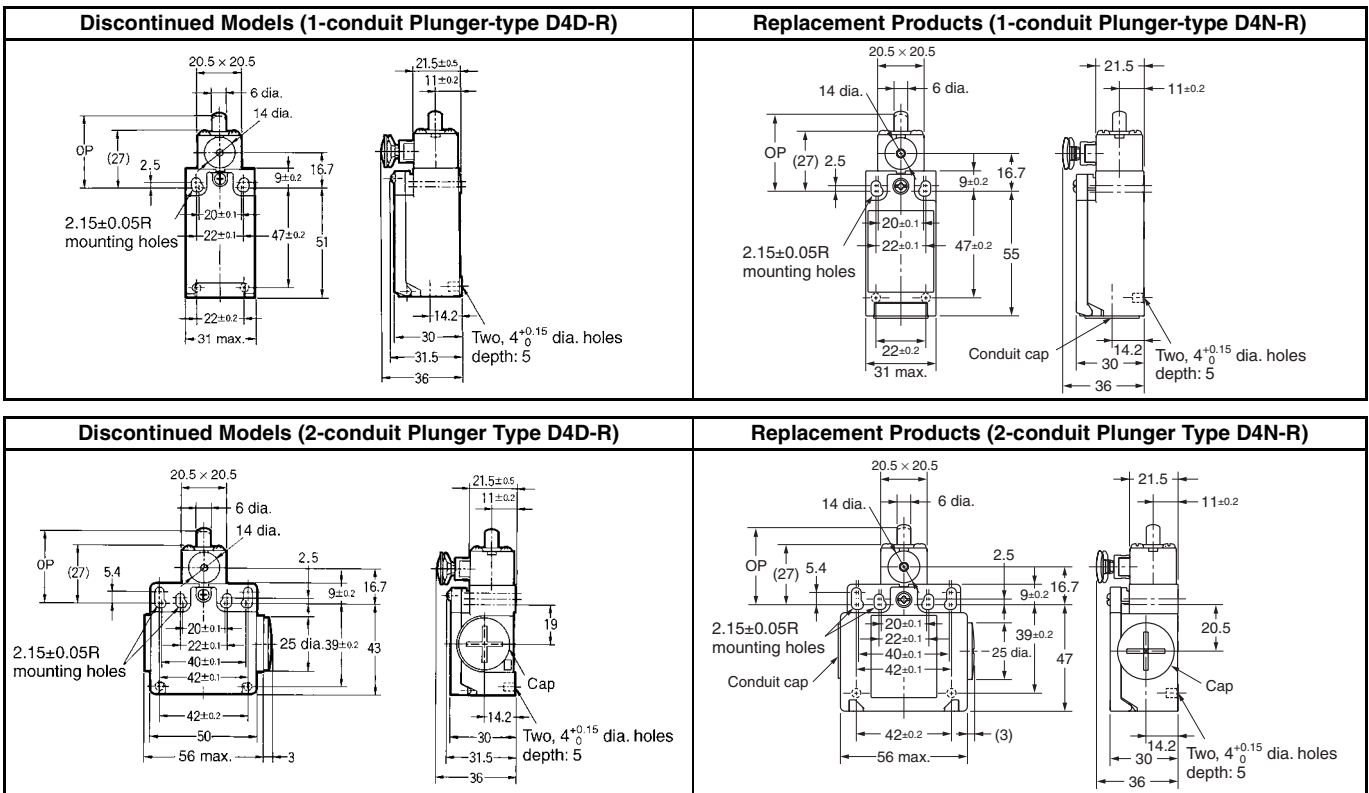

## List of Recommended Substitute Products

■ : The actuator on the D4D-R is a non-safety type. The D4N-R is recommended for safety applications (form lock type). Be sure to mount it correctly. Using M screws is recommended to comply with European standards. Therefore, the M20 conduit model is recommended for use in new designs.

### Safety Limit Switch

D4D-R product to be discontinued	Recommended substitute product	D4D-R product to be discontinued	Recommended substitute product
D4D-1520R	D4N-1A20R	D4D-1A20R	D4N-1B20R
D4D-2520R	D4N-2A20R	D4D-2A20R	D4N-2B20R
D4D-3520R	D4N-3A20R	D4D-3A20R	D4N-3B20R
D4D-5520R	D4N-5A20R	D4D-5A20R	D4N-5B20R
D4D-6520R	D4N-6A20R	D4D-6A20R	D4N-6B20R
D4D-1531R	D4N-1A31R	D4D-1A31R	D4N-1B31R
D4D-2531R	D4N-2A31R	D4D-2A31R	D4N-2B31R
D4D-3531R	D4N-3A31R	D4D-3A31R	D4N-3B31R
D4D-5531R	D4N-5A31R	D4D-5A31R	D4N-5B31R
D4D-6531R	D4N-6A31R	D4D-6A31R	D4N-6B31R
D4D-1532R	D4N-1A32R	D4D-1A32R	D4N-1B32R
D4D-2532R	D4N-2A32R	D4D-2A32R	D4N-2B32R
D4D-3532R	D4N-3A32R	D4D-3A32R	D4N-3B32R
D4D-5532R	D4N-5A32R	D4D-5A32R	D4N-5B32R
D4D-6532R	D4N-6A32R	D4D-6A32R	D4N-6B32R
D4D-1562R	D4N-1A62R	D4D-1A62R	D4N-1B62R
D4D-2562R	D4N-2A62R	D4D-2A62R	D4N-2B62R
D4D-3562R	D4N-3A62R	D4D-3A62R	D4N-3B62R
D4D-5562R	D4N-5A62R	D4D-5A62R	D4N-5B62R
D4D-6562R	D4N-6A62R	D4D-6A62R	D4N-6B62R
D4D-1572R	D4N-1A72R	D4D-1A72R	D4N-1B72R
D4D-2572R	D4N-2A72R	D4D-2A72R	D4N-2B72R
D4D-3572R	D4N-3A72R	D4D-3A72R	D4N-3B72R
D4D-5572R	D4N-5A72R	D4D-5A72R	D4N-5B72R
D4D-6572R	D4N-6A72R	D4D-6A72R	D4N-6B72R
D4D-152HR	D4N-1A2HR	D4D-1A2HR	D4N-1B2HR
D4D-252HR	D4N-2A2HR	D4D-2A2HR	D4N-2B2HR
D4D-352HR	D4N-3A2HR	D4D-3A2HR	D4N-3B2HR
D4D-1521R	D4N-1A2GR	D4D-1A21R	D4N-1B2GR
D4D-2521R	D4N-2A2GR	D4D-2A21R	D4N-2B2GR
D4D-3521R	D4N-3A2GR	D4D-3A21R	D4N-3B2GR
D4D-5521R	D4N-5A2GR	D4D-5A21R	D4N-5B2GR
D4D-6521R	D4N-6A2GR	D4D-6A21R	D4N-6B2GR
D4D-1527R	D4N-1A2HR	D4D-1A27R	D4N-1B2HR
D4D-2527R	D4N-2A2HR	D4D-2A27R	D4N-2B2HR
D4D-3527R	D4N-3A2HR	D4D-3A27R	D4N-3B2HR
D4D-5527R	D4N-5A2HR	D4D-5A27R	D4N-5B2HR
D4D-6527R	D4N-6A2HR	D4D-6A27R	D4N-6B2HR

Safety Limit Switches

D4N-□R

ALL DIMENSIONS SHOWN ARE IN MILLIMETERS.  
 To convert millimeters into inches, multiply by 0.03937. To convert grams into ounces, multiply by 0.03527.

Cat. No. C132-E1-02

In the interest of product improvement, specifications are subject to change without notice.