



Low voltage AC drives

ABB machinery drives ACS355 0.37 to 22 kW/0.5 to 30 hp Catalog

Selecting and ordering your drive

Type designation is a unique reference number that clearly identifies the drive by construction, power and voltage rating and selected options. Using the type designation you can specify your drives from the wide range of options available. Options are added to the type designation using the corresponding “plus” (+) code.

Build up your own ordering code using the type designation key below or contact your local ABB drives sales office and let them know what you want. Use page 3 as a reference section for more information.

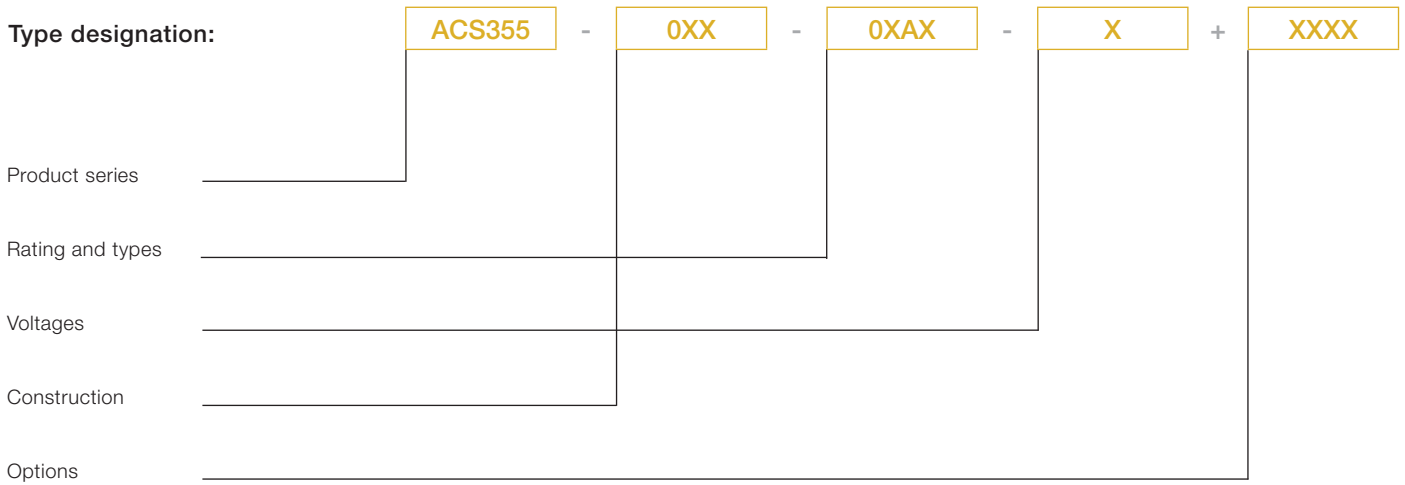

Contents

ABB machinery drives, ACS355

Introduction to ACS355	4
Main features	5
Typical applications	6
Ratings and types	7
Type designation	7
Voltages	7
Construction	7
Technical data	8
Dimensions and weights	9
Cabinet-mounted drives (IP20 UL Open)	9
Wall-mounted drives (NEMA 1/UL Type 1)	9
Wall-mounted drives (IP66/IP67/UL Type 4X)	9
Cooling and fuses	10
Control connections	11
Connection examples	11
Control program example	12
Options	14
How to select options	14
User interfaces	15
Machine interfaces	16
Extension modules	16
Protection and installation	16
Sequence programming example: radio button	17
FlashDrop tool	18
Brake resistors	18
Input and output chokes	19
EMC filters	20
Low leakage current filters	20
Compact PLC and AC drive kit	21
Services	22

Introduction to ACS355



ABB machinery drives

The ABB machinery drives are designed to be fast drives to install, parameter-set and commission. Thus saving hours of engineering work. They are highly compact and cost effective. Equipped with cutting-edge intelligence and safety capability the drives are designed specifically to meet the production and performance needs of system integrators, original equipment manufacturers (OEMs) and panel builders, as well as the requirements of end users in a broad range of applications.

In the ABB machinery drives portfolio, ACS355 represents the micro drive range; meeting requirements like compact size, being optimized for a lower power range, cost-effectiveness, and ease of use. By choosing an ABB machinery drive, machine builders not only get all the clever things inside the drive, but also everything outside it: the entire global ABB. This means a full range of products and services designed to support their business.

Applications

ABB machinery drives are designed to meet the requirements of an extensive range of machinery applications. The drives are ideal for food and beverage, material handling, lifting, textile, printing, rubber and plastics, and woodworking applications.

Highlights

- Exceptionally compact drives and uniform design
- Quick commissioning with application macros and panel assistants
- Safe torque-off function (SIL3) as standard
- Sensorless vector control for induction motors and permanent magnet motors up to 599 Hz
- Built-in braking chopper

High protection class drive

A range of ABB machinery drives with IP66 protection is designed for applications exposed to dust, moisture and cleaning chemicals such as screws, mixers, pumps, fans and conveyors. Typical industries that benefit from the drive include food and beverage, textile, ceramics, pulp and paper, water and wastewater, printing and rubber and plastics.

The heat sink's cooling fins are completely open from top to bottom, which allows easy washing to ensure no dirt adheres to the surfaces. Assistant control panel housed within a plastic window is designed to resist moist and dusty atmospheres. Furthermore, the cooling fan is located inside the drive, thereby eliminating the need for an external cooling fan and the subsequent maintenance of external moving parts.

The drive's hygienic design and use of materials meeting current hygiene standards, means that the drive traps no bacteria and can withstand frequent washing. The drive is certified by NSF.

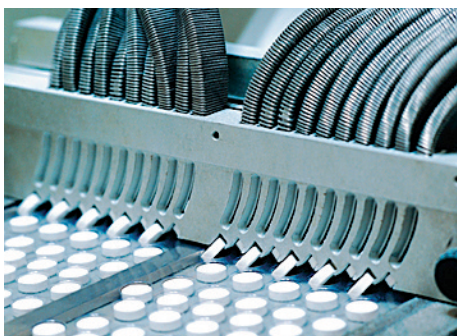

1. Textile
2. Pharmaceutical

3. Food and beverage
4. Material handling

5. Printing
6. Lifting

Main features

ACS355 - 03X - 0XAX - X + B063

Feature	Advantage	Benefit
Worldwide availability and service	Drives are available worldwide and permanently stocked in four regions. Dedicated global service and support network that is one of the widest in the industry.	Fast and reliable delivery with dedicated support to any country in the world.
Broadest power range in its class from 0.37 to 22 kW	Drive series covers all the typical needs of machine builders with a single family of machinery drive.	Cost savings as machine builders need to choose only one drive series.
Exceptionally compact drives and uniform design	Drive has the highest power density in its class at 2.8 kW/dm ³ . All frame sizes share the same depth and height facilitating multiple drive solutions and cabinet installations.	Space savings in restricted spaces.
Safe torque-off function (SIL3) as standard	Built-in and certified function that is used for prevention of an unexpected startup and other stopping related functions.	Reduces the need for external safety components Helps machine builders to fulfill the requirements of Machinery Directive 2006/42/EC.
Sequence programming	Simple drive control logic, with up to eight pre-set sequences of operations, is created in minutes with built-in sequence programming.	Reduces the need for external PLC components.
Application macros and control panel assistants	Pre-defined I/O configurations containing macros such as 3-wire, PID-control and motor potentiometer macro. Different assistants help set parameters for different functions such as drive startup, motor setup or PID control.	Enables quick commissioning of a drive.
FlashDrop tool	A pre-defined machine parameter set, from selection of up to 20, can be downloaded in seconds to a drive without powering the drive. The FlashDrop tool is easy to use and no specialized drives knowledge is required.	Fast, easy and reliable pre-configuration of drives for high-volume machine builders.
Speed compensated stop	A feature for applications that require precision stopping that is independent of variations in process speed.	Improved production flow and cost saving of a built-in feature.
Product variant for demanding environments with IP66/67/69K, UL Type 4X protection classes	No need to design special enclosure for application that requires a high ingress protection. NSF certified.	Time and cost savings.
Sensorless vector control for induction motors and permanent magnet motors	Accurate motor control without a feedback device. Patented smooth start for permanent magnet motors.	Cost saving of a reduced component. Increased energy efficiency by using PM motors.



Typical applications

Mixer

In mixing applications the drive provides a high starting torque. The silent operation mode adjusts the switching frequency of the drive to a higher level after the high-torque start, resulting in lower audible noise. The FlashDrop tool provides a quick and safe way to configure multiple drives for identical mixer applications.

Conveyor

Production lines often have multiple stages, including conveyors, which need to be efficiently linked with each other to provide high production output. A drive provides smooth start and stop of the conveyor, thereby reducing mechanical stress and lowering maintenance costs.

Packaging machine

Packaging machines often require a drive to provide a high degree of repeatability and accuracy during the packing operation. As such, the ACS355 is well suited for packaging duties and also provides good dynamic and static speed control accuracy. Sequence programming enables the drive to perform sequences of tasks, reducing the need for a PLC. Software features include timer, counter, brake control and jogging – all of which can be used in a packaging machine.

Bottling line

When filling the bottles with liquid, bottling lines require a drive which offers high accuracy. An ACS355 is perfect for this purpose, with its good dynamic and static speed control.

When dealing with liquids, an ACS355 with a high protection class (IP66) would also be a good choice.

Winder

ACS355 offers high static speed accuracy. When dealing with thin strings like in string winders, it is essential to control the winder speed accurately in order to prevent the strings from snapping. Surface winders, on the other hand, require high static speed accuracy to keep control of the material thickness or tension.



Ratings and types

ACS355 - 03E - 02A4 - 2 + B063

Type designation

This is the unique reference number (shown above and in column 4, right) that clearly identifies your drive by power rating and frame size. Once the drive's type designation has been selected, the frame size (column 5) can be used to determine the drive dimensions, shown on the next page.

Voltages

ACS355 is available in two voltage ranges:

2 = 200 to 240 V

4 = 380 to 480 V

Insert either "2" or "4", depending on your chosen voltage, into the type designation shown above.

Construction

"01E" within the type designation (shown above) varies depending on the drive phase and EMC filtering. Choose below the one you need.

01 = 1-phase

03 = 3-phase

E = EMC filter connected, 50 Hz frequency

U = EMC filter disconnected, 60 Hz frequency

(In case the filter is required it can easily be connected)

B063 = IP66/IP67/UL Type 4X enclosure

Ratings IP20 / UL Open type / NEMA 1 option			Type designation	Frame size
P_N [kW]	P_N [hp]	I_{2N} [A]		
1-phase AC supply, 200 to 240 V				
0.37	0.5	2.4	ACS355-01X-02A4-2	R0
0.75	1.0	4.7	ACS355-01X-04A7-2	R1
1.1	1.5	6.7	ACS355-01X-06A7-2	R1
1.5	2.0	7.5	ACS355-01X-07A5-2	R2
2.2	3.0	9.8	ACS355-01X-09A8-2	R2
3-phase AC supply, 200 to 240 V				
0.37	0.5	2.4	ACS355-03X-02A4-2	R0
0.55	0.75	3.5	ACS355-03X-03A5-2	R0
0.75	1.0	4.7	ACS355-03X-04A7-2	R1
1.1	1.5	6.7	ACS355-03X-06A7-2	R1
1.5	2.0	7.5	ACS355-03X-07A5-2	R1
2.2	3.0	9.8	ACS355-03X-09A8-2	R2
3.0	4.0	13.3	ACS355-03X-13A3-2	R2
4.0	5.0	17.6	ACS355-03X-17A6-2	R2
5.5	7.5	24.4	ACS355-03X-24A4-2	R3
7.5	10.0	31.0	ACS355-03X-31A0-2	R4
11.0	15.0	46.2	ACS355-03X-46A2-2	R4
3-phase AC supply, 380 to 480 V				
0.37	0.5	1.2	ACS355-03X-01A2-4	R0
0.55	0.75	1.9	ACS355-03X-01A9-4	R0
0.75	1.0	2.4	ACS355-03X-02A4-4	R1
1.1	1.5	3.3	ACS355-03X-03A3-4	R1
1.5	2.0	4.1	ACS355-03X-04A1-4	R1
2.2	3.0	5.6	ACS355-03X-05A6-4	R1
3.0	4.0	7.3	ACS355-03X-07A3-4	R1
4.0	5.0	8.8	ACS355-03X-08A8-4	R1
5.5	7.5	12.5	ACS355-03X-12A5-4	R3
7.5	10.0	15.6	ACS355-03X-15A6-4	R3
11.0	15.0	23.1	ACS355-03X-23A1-4	R3
15.0	20.0	31.0	ACS355-03X-31A0-4	R4
18.5	25.0	38.0	ACS355-03X-38A0-4	R4
22.0	30.0	44.0	ACS355-03X-44A0-4	R4

Ratings IP66/IP67/UL Type 4X			Type designation	Frame size
P_N [kW]	P_N [hp]	I_{2N} [A]		
3-phase AC supply, 200 to 240 V				
0.37	0.5	2.4	ACS355-03X-02A4-2 + B063	R1
0.55	0.75	3.5	ACS355-03X-03A5-2 + B063	R1
0.75	1.0	4.7	ACS355-03X-04A7-2 + B063	R1
1.1	1.5	6.7	ACS355-03X-06A7-2 + B063	R1
1.5	2.0	7.5	ACS355-03X-07A5-2 + B063	R1
2.2	3.0	9.8	ACS355-03X-09A8-2 + B063	R3
3.0	4.0	13.3	ACS355-03X-13A3-2 + B063	R3
4.0	5.0	17.6	ACS355-03X-17A6-2 + B063	R3
3-phase AC supply, 380 to 480 V				
0.37	0.5	1.2	ACS355-03X-01A2-4 + B063	R1
0.55	0.75	1.9	ACS355-03X-01A9-4 + B063	R1
0.75	1.0	2.4	ACS355-03X-02A4-4 + B063	R1
1.1	1.5	3.3	ACS355-03X-03A3-4 + B063	R1
1.5	2.0	4.1	ACS355-03X-04A1-4 + B063	R1
2.2	3.0	5.6	ACS355-03X-05A6-4 + B063	R1
3.0	4.0	7.3	ACS355-03X-07A3-4 + B063	R1
4.0	5.0	8.8	ACS355-03X-08A8-4 + B063	R1
5.5	7.5	12.5	ACS355-03X-12A5-4 + B063	R3
7.5	10.0	15.6	ACS355-03X-15A6-4 + B063	R3

X within the type designation stands for E or U.

P_N for kW = Typical motor power in 400 V at normal use

P_N for hp = Typical motor power in 460 V at normal use

I_{2N} for A = Continuous rms current. 50% overload is allowed for one minute in ten minutes.

Technical data

ACS355

- OXX

- OXAX

- X

+ XXXX

Mains connection	
Voltage and power range	1-phase, 200 to 240 V ± 10% 0.37 to 2.2 kW (0.5 to 3 hp) 3-phase, 200 to 240 V ± 10% 0.37 to 11 kW (0.5 to 15 hp) 3-phase, 380 to 480 V ± 10% 0.37 to 22 kW (0.5 to 30 hp)
Frequency	48 to 63 Hz
Common DC connection	
Voltage and power range	230 V drives, 325 V ± 15% 400/480 V drives, 540 ± 15% (common DC manual) $P_{max} = P_n$ of the drive
Motor connection	
Voltage	3-phase, from 0 to U_{SUPPLY}
Frequency	0 to 599 Hz
Continuous loading capability (constant torque at a max. ambient temperature of 40 °C)	Rated output current I_{2N}
Overload capacity (at a max. ambient temperature of 40 °C)	1.5 x I_{2N} for 1 minute every 10 minutes At start 1.8 x I_{2N} for 2 s
Switching frequency Selectable	Default 4 kHz 4 to 16 kHz with 4 kHz steps
Acceleration time	0.1 to 1800 s
Deceleration time	0.1 to 1800 s
Braking	Built-in brake chopper as standard
Speed control	
Static accuracy	20% of motor nominal slip
Dynamic accuracy	< 1% s with 100% torque step
Torque control	
Torque step rise time	< 10 ms with nominal torque
Non-linearity	± 5% with nominal torque
Environmental limits	
Ambient temperature	-10 to 40 °C (14 to 104 °F), no frost allowed 50 °C (122 °F) with 10% derating
Altitude	Rated current available at 0 to 1000 m. In altitudes from 1000 to 2000 m (3300 to 13,200 ft) above sea level, the derating is 1% for every 100 m (330 ft). If the installation site is higher than 2000 m (6600 ft) above sea level, please contact your local ABB distributor or office for further information.
Relative humidity	Lower than 95% (without condensation)
Degree of protection	IP20/optional NEMA 1/UL type 1 enclosure IP66/IP67/UL Type 4X as an option up to 7.5 kW, IP69K available for IP66/IP67 variant with compatible cable glands
Enclosure colour	NCS 1502-Y, RAL 9002, PMS 420 C
Contamination levels	IEC721-3-3 No conductive dust allowed
Transportation	Class 1C2 (chemical gases) Class 1S2 (solid particles)
Storage	Class 2C2 (chemical gases) Class 2S2 (solid particles)
Operation	Class 3C2 (chemical gases) Class 3S2 (solid particles)
Product compliance	
Low Voltage Directive 2006/95/EC Machinery Directive 2006/42/EC EMC Directive 2004/108/EC Quality assurance system ISO 9001 Environmental system ISO 14001 UL, cUL, CE, C-Tick and GOST R approvals RoHS compliant	

Programmable control connections	
Two analog inputs	
Voltage signal	
Unipolar	0 (2) to 10 V, $R_{in} > 312 \text{ k}\Omega$
Bipolar	-10 to 10 V, $R_{in} > 312 \text{ k}\Omega$
Current signal	
Unipolar	0 (4) to 20 mA, $R_{in} = 100 \Omega$
Bipolar	-20 to 20 mA, $R_{in} = 100 \Omega$
Potentiometer reference value	10 V ± 1% max. 10 mA, $R < 10 \text{ k}\Omega$
Resolution	0.1%
Accuracy	± 2%
One analog output	0 (4) to 20 mA, load < 500 Ω
Auxiliary voltage	24 V DC ± 10%, max. 200 mA
Five digital inputs	12 to 24 V, PNP and NPN, programmable DI5 0 to 16 kHz pulse train 2.4 k Ω
Input impedance	
One relay output	
Type	NO + NC
Maximum switching voltage	250 V AC/30 V DC
Maximum switching current	0.5 A/30 V DC; 5 A/230 V AC
Maximum continuous current	2 A rms
One digital output	
Type	Transistor output
Maximum switching voltage	30 V DC
Maximum switching current	100 mA/30 V DC, short circuit protected
Frequency	10 Hz to 16 kHz
Resolution	1 Hz
Accuracy	0.2%
Serial and Ethernet communication	
Fieldbuses	Plug-in type
Refresh rate	< 10 ms (between drive and fieldbus module)
DeviceNet™	5-pin screw type connector, up to 500 kbit/s baud rate
PROFIBUS DP	9-pin D-connector, up to 12 Mbit/s baud rate
CANopen®	9-pin D-connector, up to 1 Mbit/s
Modbus RTU	4-pin screw type connector, up to 115 kbit/s baud rate
EtherNet/IP™, Modbus TCP, PROFINET IO	RJ-45 connector, 10/100 Mbit/s baud rate
LonWorks®	3-pin screw type connector, up to 78 kbit/s baud rate
EtherCAT®	2 pcs RJ-45 connectors, 100 Mbit/s baud rate
Chokes	
AC input chokes	External option. For reducing THD in partial loads and to comply with EN/IEC 61000-3-12.
AC output chokes	External option. To achieve longer motor cables.
Mains connection, high protection class drive	
Voltage and power range	3-phase, 200 to 240 V ± 10% 0.37 to 4 kW (0.5 to 5 hp) 3-phase, 380 to 480 V ± 10% 0.37 to 7.5 kW (0.5 to 10 hp)
Environmental limits, high protection class drive	
Ambient temperature	-10 to 40 °C (14 to 104 °F), no frost allowed
Degree of protection	IP66/IP67/UL Type 4X, indoor use only IP69K with compatible cable glands
Product compliance, high protection class drive	
Low Voltage Directive 2006/95/EC Machinery Directive 2006/42/EC EMC Directive 2004/108/EC Quality assurance system ISO 9001 Environmental system ISO 14001 UL, cUL, CE, C-Tick and GOST R approvals RoHS compliant NSF Certified DIN40050-9 (IP69K)	

Dimensions and weights

ACS355 - OXX - OXAX - X + XXXX

Cabinet-mounted drives (IP20 UL Open)

Frame size	IP20 UL Open						Weight kg
	H1 mm	H2 mm	H3 mm	W mm	D1 mm	D2 mm	
R0	169	202	239	70	161	187	1.2
R1	169	202	239	70	161	187	1.2
R2	169	202	239	105	165	191	1.5
R3	169	202	236	169	169	195	2.5
R4	181	202	244	260	169	195	4.4

H1 = Height without fastenings and clamping plate
 H2 = Height with fastenings but without clamping plate
 H3 = Height with fastenings and clamping plate
 W = Width
 D1 = Standard depth
 D2 = Depth with MREL, MPOW or MTAC option

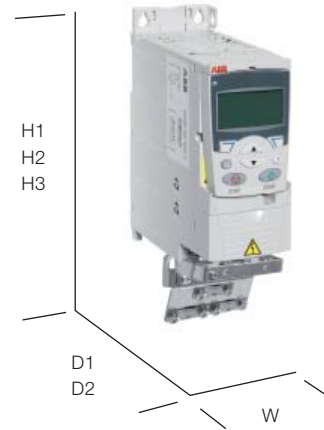

Wall-mounted drives (NEMA 1/UL Type 1)

Frame size	NEMA 1/UL Type 1					Weight kg
	H4 mm	H5 mm	W mm	D1 mm	D2 mm	
R0	257	280	70	169	187	1.6
R1	257	280	70	169	187	1.6
R2	257	282	105	169	191	1.9
R3	260	299	169	177	195	3.1
R4	270	320	260	177	195	5.0

H4 = Height with fastenings and NEMA 1 connection box
 H5 = Height with fastenings, NEMA 1 connection box and hood
 W = Width
 D1 = Standard depth
 D2 = Depth with MREL, MPOW or MTAC option

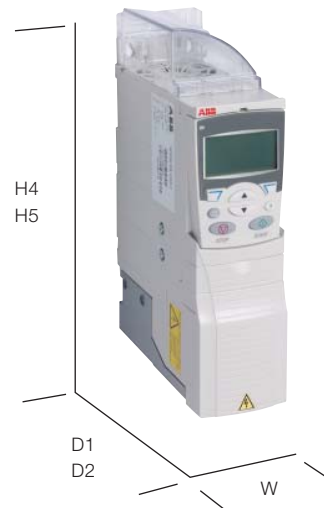

Wall-mounted drives (IP66/IP67/UL Type 4X)

Frame size	IP66/IP67/UL Type 4X			
	H mm	W mm	D1 mm	Weight kg
R1	305	195	281	7.7
R3	436	246	277	13

H = Height
 W = Width
 D1 = Standard depth



Cooling and fuses

Cooling

ACS355 is fitted with cooling fans as standard. The cooling air must be free from corrosive substances and must not be above the maximum ambient temperature of 40 °C (50 °C with derating). Heat dissipation from IP66/IP67/UL Type 4X drive equals to the IP20 UL Open values. For more specific limits see the Technical specification - Environmental limits in this catalog.

Cooling air flow

Type designation	Frame size	Heat dissipation		Air flow	
		[W]	BTU/hr ¹⁾	m ³ /h	ft ³ /min
1-phase AC supply, 200 to 240 V					
ACS355-01X-02A4-2	R0	48	163	- ²⁾	- ²⁾
ACS355-01X-04A7-2	R1	72	247	24	14
ACS355-01X-06A7-2	R1	97	333	24	14
ACS355-01X-07A5-2	R2	101	343	21	12
ACS355-01X-09A8-2	R2	124	422	21	12
3-phase AC supply, 200 to 240 V					
ACS355-03X-02A4-2	R0	42	142	- ²⁾	- ²⁾
ACS355-03X-03A5-2	R0	54	183	- ²⁾	- ²⁾
ACS355-03X-04A7-2	R1	64	220	24	14
ACS355-03X-06A7-2	R1	86	295	24	14
ACS355-03X-07A5-2	R1	88	302	21	12
ACS355-03X-09A8-2	R2	111	377	21	12
ACS355-03X-13A3-2	R2	140	476	52	31
ACS355-03X-17A6-2	R2	180	613	52	31
ACS355-03X-24A4-2	R3	285	975	71	42
ACS355-03X-31A0-2	R4	328	1119	96	57
ACS355-03X-46A2-2	R4	488	1666	96	57
3-phase AC supply, 380 to 480 V					
ACS355-03X-01A2-4	R0	35	121	- ²⁾	- ²⁾
ACS355-03X-01A9-4	R0	40	138	- ²⁾	- ²⁾
ACS355-03X-02A4-4	R1	50	170	13	8
ACS355-03X-03A3-4	R1	60	204	13	8
ACS355-03X-04A1-4	R1	69	235	13	8
ACS355-03X-05A6-4	R1	90	306	19	11
ACS355-03X-07A3-4	R1	107	364	24	14
ACS355-03X-08A8-4	R1	127	433	24	14
ACS355-03X-12A5-4	R3	161	551	52	31
ACS355-03X-15A6-4	R3	204	697	52	31
ACS355-03X-23A1-4	R3	301	1029	71	42
ACS355-03X-31A0-4	R4	408	1393	96	57
ACS355-03X-38A0-4	R4	498	1700	96	57
ACS355-03X-44A0-4	R4	588	2007	96	57

X within the type designation stands for E or U.

¹⁾ BTU/hr = British Thermal Unit per hour. BTU/hr is approximately 0.293 Watts.

²⁾ Frame size R0 with free convection cooling.

Free space requirements

Enclosure type	Space above	Space below	Space on left/right
	mm	mm	mm
All frame sizes	75	75	0
IP66/67 enclosure	75	75	20

Fuses

Standard fuses can be used with ABB machinery drives. For input fuse connections see table below.

Selection table

Type designation	Frame size	IEC fuses		UL fuses	
		[A]	Fuse type ^{*)}	[A]	Fuse type ^{*)}
1-phase AC supply, 200 to 240 V					
ACS355-01X-02A4-2	R0	10	gG	10	UL class T
ACS355-01X-04A7-2	R1	16	gG	20	UL class T
ACS355-01X-06A7-2	R1	16/20 ¹⁾	gG	25	UL class T
ACS355-01X-07A5-2	R2	20/25 ¹⁾	gG	30	UL class T
ACS355-01X-09A8-2	R2	25/35 ¹⁾	gG	35	UL class T
3-phase AC supply, 200 to 240 V					
ACS355-03X-02A4-2	R0	10	gG	10	UL class T
ACS355-03X-03A5-2	R0	10	gG	10	UL class T
ACS355-03X-04A7-2	R1	10	gG	15	UL class T
ACS355-03X-06A7-2	R1	16	gG	15	UL class T
ACS355-03X-07A5-2	R1	16	gG	15	UL class T
ACS355-03X-09A8-2	R2	16	gG	20	UL class T
ACS355-03X-13A3-2	R2	25	gG	30	UL class T
ACS355-03X-17A6-2	R2	25	gG	35	UL class T
ACS355-03X-24A4-2	R3	63	gG	60	UL class T
ACS355-03X-31A0-2	R4	80	gG	80	UL class T
ACS355-03X-46A2-2	R4	100	gG	100	UL class T
3-phase AC supply, 380 to 480 V					
ACS355-03X-01A2-4	R0	10	gG	10	UL class T
ACS355-03X-01A9-4	R0	10	gG	10	UL class T
ACS355-03X-02A4-4	R1	10	gG	10	UL class T
ACS355-03X-03A3-4	R1	10	gG	10	UL class T
ACS355-03X-04A1-4	R1	16	gG	15	UL class T
ACS355-03X-05A6-4	R1	16	gG	15	UL class T
ACS355-03X-07A3-4	R1	16	gG	20	UL class T
ACS355-03X-08A8-4	R1	20	gG	25	UL class T
ACS355-03X-12A5-4	R3	25	gG	30	UL class T
ACS355-03X-15A6-4	R3	35	gG	35	UL class T
ACS355-03X-23A1-4	R3	50	gG	50	UL class T
ACS355-03X-31A0-4	R4	80	gG	80	UL class T
ACS355-03X-38A0-4	R4	100	gG	100	UL class T
ACS355-03X-44A0-4	R4	100	gG	100	UL class T

X within the type designation stands for E or U.

^{*)} According to IEC-60269 standard.

¹⁾ If 50% overload capacity is needed, use the bigger fuse alternative.

Control connections



Application macros

Application macros are preprogrammed parameter sets. While starting up the drive, the user typically selects one of the macros that is best suited for the application. The diagram below gives an overview of ACS355 control connections and shows the default I/O connections for the ABB standard macro.

- Alternate macro
- AC500 Modbus macro
- Motor potentiometer macro
- Hand/auto macro
- PID control macro

ABB machinery drives have eight application macros:

- ABB standard macro
- Torque control macro
- 3-wire macro

In addition to the standard macros the user can create three user macros. The user macro allows the user to save the parameter settings for later use.

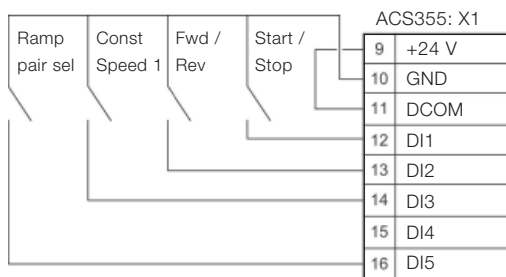
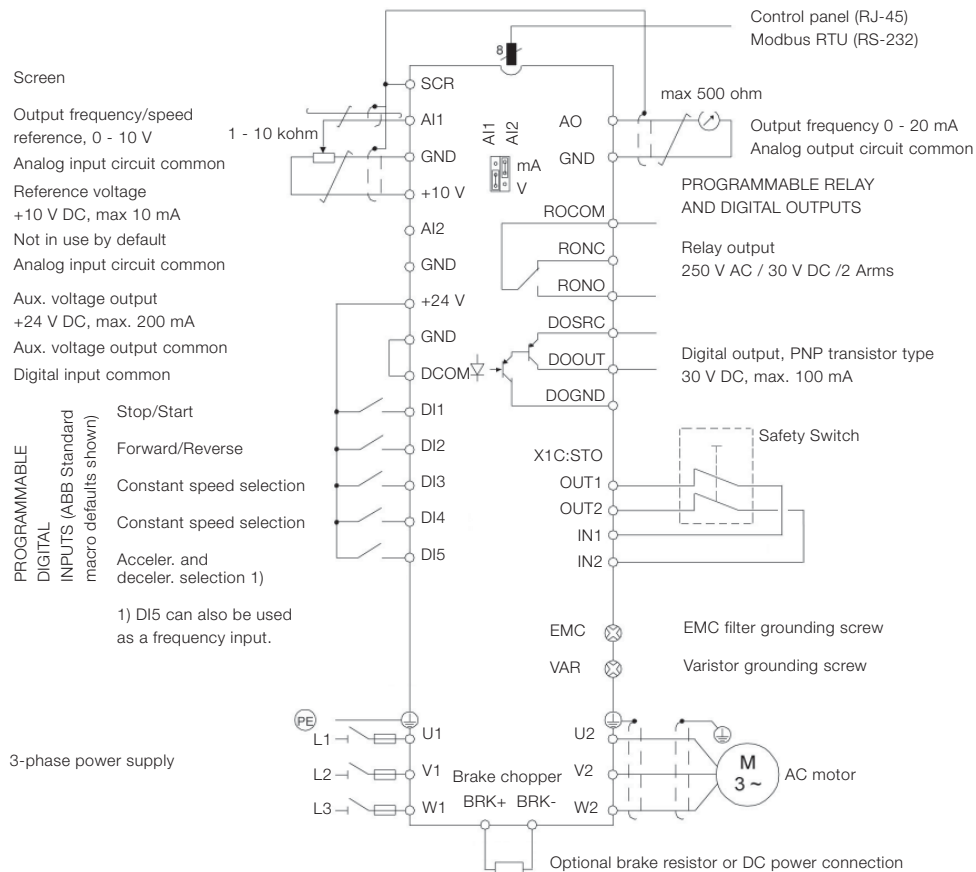

Sinking DI configuration (NPN connected).

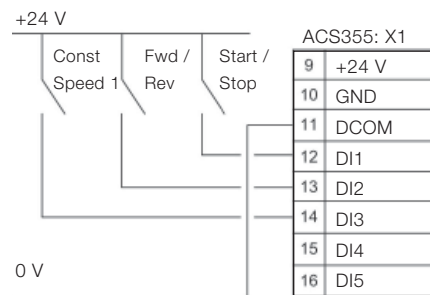

Sourcing DI configuration (PNP connected) with external power supply.

Control program example

ACS355 - 0XX - 0XAX - X + XXXX

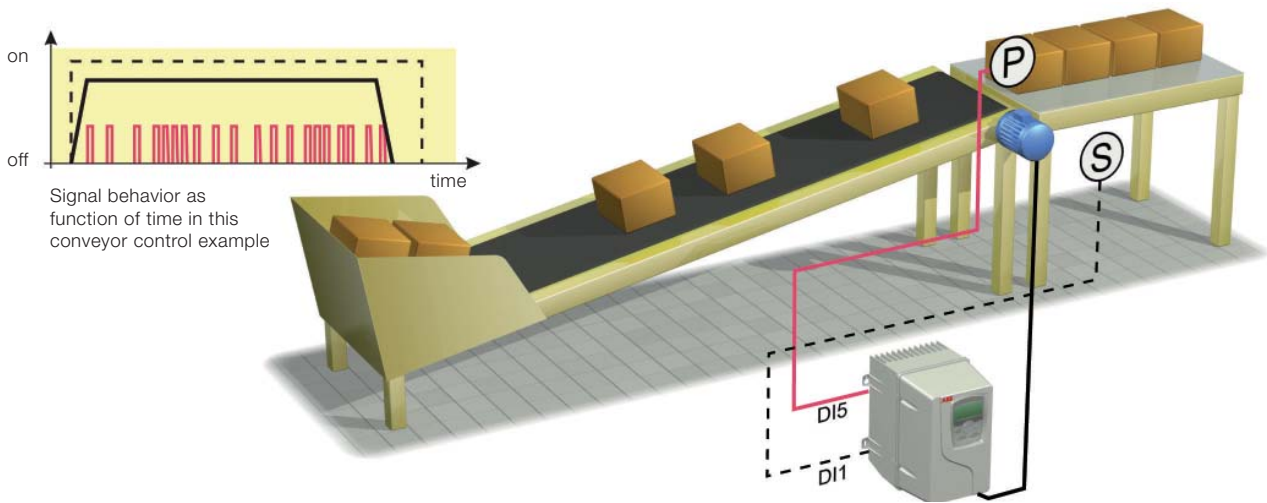

The ACS355 drives have many solutions for common challenges. The following example explains how the COUNTER STOP function operates within a conveyor unloading routine. The function stops the conveyor after a predefined number of boxes have passed the sensor.

The operator starts the conveyor by activating the drive using switch, S. The switch is connected to digital input 1 (D1). The drive accelerates to a constant speed of 30 Hz with a 1 second ramp time.

Meanwhile a sensor, or proximity switch, P, is connected to digital input 5 (DI5). This sensor generates one pulse, every time a box on the conveyor passes by. When the required number of boxes – in this case 20 – have passed the sensor, the drive stops with a 1 second ramp time.

Parameter settings

Startup data

The correct motor parameters are set within parameter group 99. However, if the current and voltage settings of the motor and drive match, this is not necessary. The ACS355 also features vector control, which can be used by setting the relevant parameters and undertaking an ID run.

Start/Stop/Direction logic

Parameter 1001 EXT1 COMMANDS is set to COUNTER STOP [24]. Under certain conditions the counter output will modify the start/stop signal for stopping.

Constant speed selection

Parameter 1201 CONST SPEED SEL is set to DI1 [1]. Parameter 1202 CONST SPEED 1 acts as a speed reference source when digital input 1 is active.

Parameter 1202 CONST SPEED 1 is set to 30 Hz.

Start/Stop functions

Parameter 2101 START FUNCTION is set to AUTO [1], which is also the default value. If high torque is required for the conveyor to start, settings DC MAGN [2] can be used.

Parameter 2102 STOP FUNCTION is set to RAMP [2]. Thus the drive ramps down to 0 at a stop command.

Counter parametrization

Parameter 1904 COUNTER ENABLE is set to DI1 [1]. Counter is enabled now by digital input 1. When digital input 1 is low, the counter is not counting.

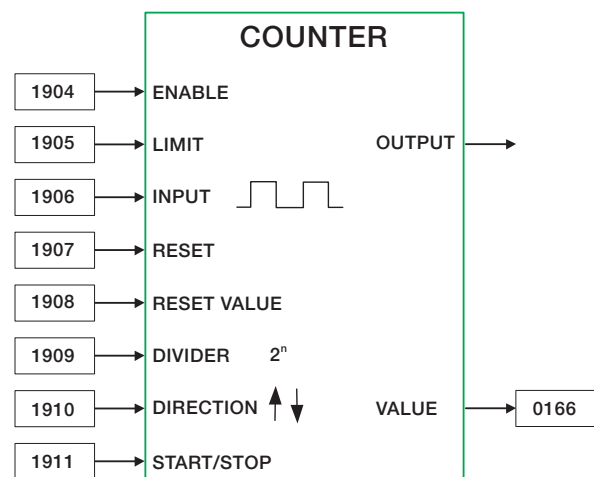

Control program example



Parameter 1905 COUNTER LIMIT is set to 20. In this example the loading station can only hold 20 boxes.

Parameter 1906 COUNTER INPUT is set to PLS IN (DI5) [1] which is also the default value. Pulse counter P is wired to digital input (DI5). This digital input can also handle high frequency pulses up to 10 kHz. If the counter signal edges are swinging, this parameter can be set to FILTERED DI5 [4].

Parameter 1907 COUNTER RESET is set to DI1 (INV) [-1]. When digital input 1 is low, the counter is reset to a value determined by parameter 1908 COUNTER RES VAL.

Parameter 1908 COUNTER RES VAL is set to zero, which is also the default value. The counter, in this example, runs from 0 to 20.

Parameter 1909 COUNT DIVIDER is set to zero, which is also the default value. This value is used to divide high frequency pulse numbers to lower values. For example a 1024 pulse incremental encoder would give 1024 pulses in one revolution. When using count divider 10 (2 to the power of 10) the counter would count up by 1 after 1024 pulses.

Parameter 1910 COUNT DIRECTION is set to UP [0], which is also the default value.

Parameter 1911 CNTR S/S COMMAND is set to DI1 [1]. Digital input 1 acts as the drive start command. Due to the setting of parameter 1001 EXT1 COMMANDS, the drive stops when the counter limit has been reached or digital input 1 goes low.

The counter's actual value can now be seen from signal 0166.

Acceleration and deceleration settings

Parameter 2201 ACC/DEC 1/2 SEL is set to NOT SEL [0]. Only one ramp is used in this application, thereby ramp changing is disabled.

Parameter 2202 ACCELER TIME 1 is set to 1s.

Parameter 2203 DECELER TIME 2 is set to 1s.

ACS355 control program functions

ACS355 control program provides the following functions:

- Counter start and stop
- Timer start and stop
- Speed compensated stop
- 3 independent supervision functions
- Automatic restart function
- 2 sets of ramping times
- S-curve for ramping
- 7 constant speeds
- 3 critical speed ranges
- Maintenance triggers
- Timed functions
- Configurable fault/protection functions
- 2 process PID functions
- PID sleep function
- PID trim function
- Mechanical brake control
- 8 state sequence programming
- 2 sets of user parameter sets
- Safe torque-off
- Parameter lock

The ACS355 features the following motor control functions:

- Current, torque, speed and frequency limits
- Under- and overvoltage controllers
- Starting to the rotating machine
- Linear, squared and user defined U/f curves for scalar control
- IR compensation for scalar control
- Flux optimization for energy saving
- Flux braking for improved ramping down
- Drive temperature controlled switching frequency control
- Motor noise smoothing
- Sensorless vector control for induction motors
- Sensorless vector control for permanent magnet motors
- Smooth starting function for permanent magnet motors
- PID speed controller in vector controlled mode
- Acceleration compensation
- Speed controller auto tune
- Standalone and rotating motor identification runs
- Optional speed feed back for closed loop vector control

Options

ACS355 - OXX - OXAX - X + XXXX

How to select options

The options shown in the table are available within the ACS355 range. The ordering code, which is shown in the second column, replaces the XXXX in the type designation above. You can order as many options as required, simply by extending the code as necessary.

Options	Ordering code	Description	Model	Availability	
				IP20 drive	IP66/67 drive
Protection class	ʹ	NEMA 1/UL type 1 (R0, R1, R2)	MUL1-R1	■	-
	ʹ	NEMA 1/UL type 1 (R3)	MUL1-R3	■	-
	ʹ	NEMA 1/UL type 1 (R4)	MUL1-R4	■	-
	B063	IP66/IP67/UL type 4X enclosure		-	■
Control panel (choose one option only)	J400	Assistant control panel	ACS-CP-A	□	●
	J404	Basic control panel	ACS-CP-C	□	-
Panel mounting kit	ʹ	Panel mounting kit	ACS/H-CP-EXT	□	-
	ʹ	Panel holder mounting kit	OPMP-01	□	-
Potentiometer	J402	Potentiometer	MPOT-01	□	-
Fieldbus (choose one option only)	K451	DeviceNet™	FDNA-01	□	□
	K454	PROFIBUS DP	FPBA-01	□	□
	K457	CANopen®	FCAN-01	□	□
	K458	Modbus RTU	FMBA-01	□	□
	K466	EtherNet/IP™, Modbus TCP, PROFINET IO	FENA-01	□	□
	K452	LonWorks®	FLON-01	□	□
	K469	EtherCAT®	FECA-01	□	□
	ʹ	RS-485/Modbus	FRSA-00	□	□
Extension modules (choose one option only)	L502	Speed encoder module	MTAC-01	□	-
	L511	Relay output module	MREL-01	□	-
	G406	Auxiliary power extension module	MPOW-01	□	-
Remote monitoring	ʹ	Ethernet adapter	SREA-01	□	□
Connection options	H376	Cable gland kit (IP66/IP67/UL Type 4X)		-	□
	F278	Input switch kit		-	□
Pressure compensation	C169	Pressure compensation valve		-	□
Tools	ʹ	FlashDrop tool	MFDT-01	□	□
	ʹ	DriveWindow Light	DriveWindow Light	□	□
External options	ʹ	Input chokes		□	□ ¹⁾
	ʹ	EMC filters		□	□ ¹⁾
	ʹ	Braking resistors		□	□ ¹⁾
	ʹ	Output chokes		□	□ ¹⁾

● = standard

■ = product variant

□ = option, external

- = not available

ʹ = To be ordered as a separate item.

¹⁾ External options not available in IP66/IP67/UL Type 4X protection class.

Options Interface



User interfaces

Panel cover

The purpose of the panel cover is to protect the drive's connection surfaces. The ACS355 drive is delivered with a panel cover as standard. In addition there are two alternative control panels available as options.

Basic control panel

The basic control panel features a single line numeric display. The panel can be used to control the drive, set the parameter values or copy them from one drive to another.

Assistant control panel

The assistant control panel features a multilingual alphanumeric display for easy drive programming. The control panel has various assistants and an built-in help function to guide the user. It includes a real time clock, which can be used during fault logging and in controlling the drive, such as start/stop. The control panel can be used for copying parameters for back up or for downloading to another drive. A large graphical display and soft keys make it extremely easy to navigate. The drive with IP66/IP67 enclosure has the assistant control panel as standard.

Potentiometer

Potentiometer MPOT-01 with two switches: start/stop and forward/reverse. Polarity is selected with DIP switches. No external power source is needed for the potentiometer.

Panel mounting kits

To attach the control panel to the outside of a larger enclosure, two panel mounting kits are available. A simple and cost-efficient installation is possible with the ACS/H-CP-EXT kit, while the OPMP-01 kit provides a more user-friendly solution, including a panel platform that enables the panel to be removed in the same way as a drive-mounted panel. The panel mounting kits include all hardware required eg, 3 m extension cables and installation instructions.



Panel cover (included as standard)



Basic control panel



Assistant control panel



Potentiometer



Panel holder mounting kit OPMP-01

Options Interface



Fieldbus module

NEMA 1/UL type 1 kit

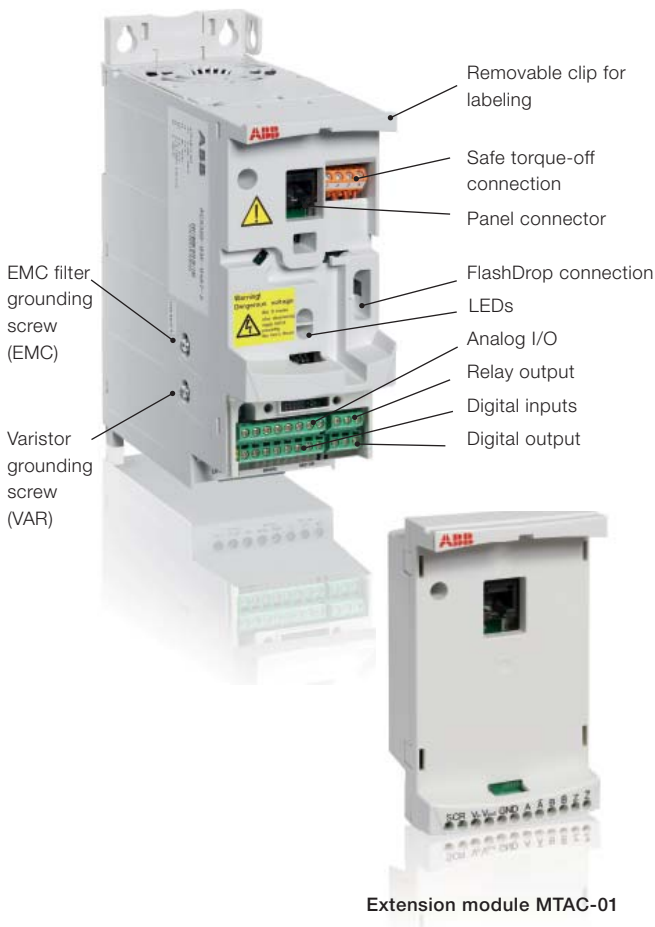

Extension module MTAC-01

Machine interfaces

The plug-in fieldbus modules bring connectivity to major automation systems. A single twisted pair cable avoids large amounts of conventional cabling, thereby reducing costs and increasing system reliability.

ACS355 supports the following fieldbus options:

- PROFIBUS DP
- CANopen®
- DeviceNet™
- Modbus RTU
- EtherNet/IP™, Modbus TCP, PROFINET IO
- LonWorks®
- EtherCAT®

Extension modules

MREL-01

ACS355 has one relay output as standard. The optional MREL-01 module offers three additional relay outputs, which can be configured for different functions with parameters.

MTAC-01

The optional MTAC-01 module offers pulse encoder interface for speed measurement.

MPOW-01

The optional auxiliary power module MPOW-01 enables the drive control circuitry to be operated under all conditions.

Protection and installation

NEMA 1/UL Type 1 kit

The NEMA 1/UL Type 1 kit includes a connection box for finger protection, conduit tube installation, and a hood for protection against dirt and dust.

Terminal cover

The terminal cover is for protection of the I/O connections.

Clamping plates

The clamping plates are used for protection against electrical disturbances. The clamping plates with clamps are included in the drive package as standard.

Options

Software tools

A separate order line and type code is required for any of these software tool options.

DriveWindow Light

DriveWindow Light is an easy-to-use commissioning and maintenance tool for ACS355 drives. It can be used in an offline mode, which enables parameter setting at the office even before going to the actual site. The parameter browser enables viewing, editing and saving of parameters. The parameter comparison feature makes it possible to compare parameter values between the drive and saved parameter files. With the parameter subset you can create your own parameter sets. Controlling of the drive is naturally one of the features in DriveWindow Light. With this software tool, you can monitor up to four signals simultaneously. This can be done in both graphical and numerical format. Any signal can be set to stop the monitoring from a predefined level.

Sequence programming tool

DriveWindow Light allows the user to visually build and manipulate sequence programming parameters that are loaded into the ACS355. The programming is done in a graphical editor which displays each sequence step and its transitions as an individual block.

Sequence programming enables application specific programming with up to 8 configurable sequences. This new and easy way to preset sequences reduces the need for an external programmable logic control (PLC). In simple applications an external PLC can be left out.

Startup wizards

Startup wizards make the setting of parameters easy. Simply launch the wizard, select an appropriate assistant eg, for setting analog outputs, and all parameters related to this function are shown together with help pictures.

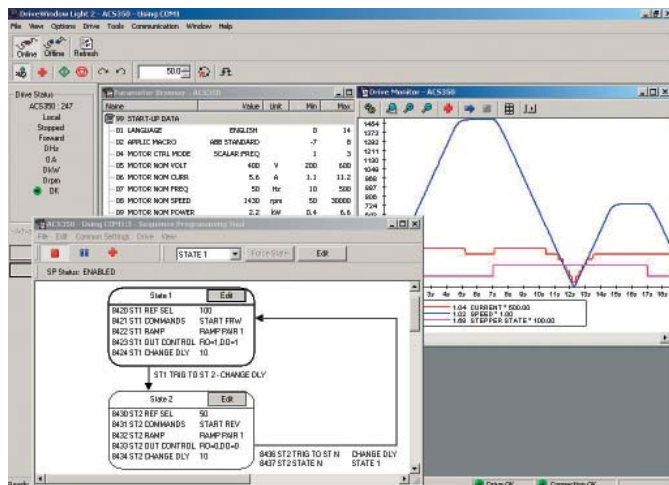

Highlights

- Graphical sequence programming tool for ACS355
- Editing, saving and downloading parameters
- Graphical and numerical signal monitoring
- Drive control
- Startup wizards

DriveWindow Light requirements

- Windows NT/2000/XP/Vista/7
- Free serial port from a PC
- Free control panel connector

Sequence programming example: radio button

In this example, analog input AI1 will start the motor at a fixed speed. This function is useful when the drive is operated using only a potentiometer. The motor speed is proportional to the analog input when analog input level is higher than the fixed level. In this case separate start and stop commands are not needed.

The analog input level is monitored using the ACS355's supervision function. Supervision function status is set as a transition rule between the two states of the sequence program.

In state 1 the drive is in stand-by, monitoring the AI1 level. In state 2 the drive starts in the forward direction and its reference is from AI1. In state 2, the supervision function monitors the AI1 level. If the value falls below the set limit, the sequence program makes a transition to state 1 and the drive is stopped.

There are two ramp pairs from which different ramping times can be selected within each state. It is also possible within the sequence program to control the analog output, digital output and relay output independently.

Supervision function, AI1 scaling to speed reference, and ramp times, can be set independent of the sequence program.

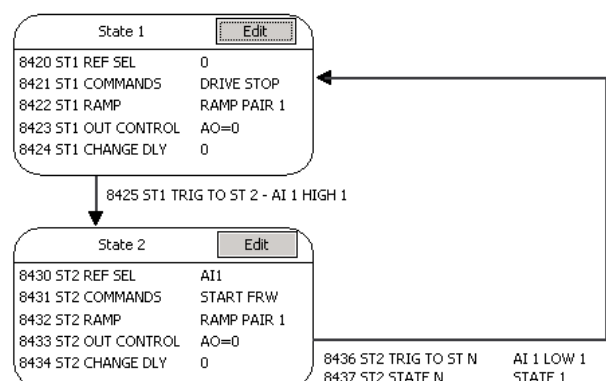

Options External

A separate order line and type designation is required for any of these external options.

FlashDrop tool

FlashDrop is a powerful palm sized tool for fast and easy parameter selecting and setting. It gives the possibility to hide selected parameters to protect the machine. Only the parameters needed in the application are shown. The tool can copy parameters between two drives or between a PC and a drive. All the above can be done without a power connection to the drive – in fact, it is not even necessary to unpack the drive.

DrivePM

DrivePM (drive parameter manager) is a tool to create, edit and copy parameter sets for the FlashDrop tool. For each parameter/group the user has a possibility to hide it, which means that the drive user does not see the parameter/group at all.

DrivePM requirements

- Windows 2000/XP/Vista/7
- Free serial port from a PC

FlashDrop package includes

- FlashDrop tool
- DrivePM software on a CD-rom
- User's manual in English and in pdf-format on the CD-rom
- Cable OPCA-02 for connection between the PC and FlashDrop tool
- Battery charger



Brake resistors

ACS355 is delivered with an integrated brake chopper as standard. Therefore no additional space or installation time is needed. The brake resistor is selected using the table below. For more information about the selection of brake resistors, see the ACS355 user's manual.

Brake chopper limits and resistor selection table

Type designation ACS355-	R_{min} [ohm]	P_{BRmax}		Selection table by resistor type						Braking time ¹⁾ [s]
		[kW]	[hp]	CBR-V / CBT-H						
				160	210	260	460	660	560	
1-phase AC supply, 200 to 240 V										
01X-02A4-2	70	0.37	0.5	●						90
01X-04A7-2	40	0.75	1	●						45
01X-06A7-2	40	1.1	1.5	●						28
01X-07A5-2	30	1.5	2	●						19
01X-09A8-2	30	2.2	3	●						14
3-phase AC supply, 200 to 240 V										
03X-02A4-2	70	0.37	0.5	●						90
03X-03A5-2	70	0.55	0.75	●						60
03X-04A7-2	40	0.75	1	●						42
03X-06A7-2	40	1.1	1.5	●						29
03X-07A5-2	30	1.5	2	●						19
03X-09A8-2	30	2.2	3	●						14
03X-13A3-2	30	3	4				●			16
03X-17A6-2	30	4	5				●			12
03X-24A4-2	18	5.5	7.5						●	45
03X-31A0-2	7	7.5	10						●	35
03X-46A2-2	7	11	15						●	23
3-phase AC supply, 380 to 480 V										
03X-01A2-4	200	0.37	0.5		●					90
03X-01A9-4	175	0.55	0.75		●					90
03X-02A4-4	165	0.75	1		●					60
03X-03A3-4	150	1.1	1.5		●					37
03X-04A1-4	130	1.5	2		●					27
03X-05A6-4	100	2.2	3		●					17
03X-07A3-4	70	3	4				●			29
03X-08A8-4	70	4	5				●			20
03X-12A5-4	40	5.5	7.5				●			15
03X-15A6-4	40	7.5	10				●			10
03X-23A1-4	30	11	15					●		10
03X-31A0-4	16	15	20						●	16
03X-38A0-4	13	18.5	25						●	13
03X-44A0-4	13	22	30						●	10

X within the type designation stands for E or U.

¹⁾ Braking time = Maximum allowed braking time in seconds at P_{BRmax} every 120 seconds, at 40 °C ambient temperature

Ratings by resistor type	CBR-V 160	CBR-V 210	CBR-V 260	CBR-V 460	CBR-V 660	CBT-H 560
Nominal power [W]	280	360	450	790	1130	2200
Resistance [ohm]	70	200	40	80	33	18

Options External

A separate order line and type designation is required for any of these external options.

Input chokes

Input choke smooths the wave shape of mains current and reduces total harmonic distortion (THD). Together with the input choke, the ACS355 is designed to fulfill the requirements of the harmonics standard EN/IEC 61000-3-12. In addition, the input choke provides improved protection against mains voltage transients.

Type designation ACS355-	Frame size	Input choke	I_{IN} without choke [A]	I_{IN} with choke [A]	I_{TH} [A]	L [mH]
1-phase AC supply, 200 to 240 V						
01X-02A4-2	R0	CHK-A1	6.1	4.5	5	8.0
01X-04A7-2	R1	CHK-B1	11.4	8.1	10	2.8
01X-06A7-2	R1	CHK-C1	16.1	11	16	1.2
01X-07A5-2	R2	CHK-C1	16.8	12	16	1.2
01X-09A8-2	R2	CHK-D1	21	15	25	1.0
3-phase AC supply, 200 to 240 V						
03X-02A4-2	R0	CHK-01	4.3	2.2	4.2	6.4
03X-03A5-2	R0	CHK-02	6.1	3.6	7.6	4.6
03X-04A7-2	R1	CHK-03	7.6	4.8	13	2.7
03X-06A7-2	R1	CHK-03	11.8	7.2	13	2.7
03X-07A5-2	R1	CHK-04	12	8.2	22	1.5
03X-09A8-2	R2	CHK-04	14.3	11	22	1.5
03X-13A3-2	R2	CHK-04	21.7	14	22	1.5
03X-17A6-2	R2	CHK-04	24.8	18	22	1.5
03X-24A4-2	R3	CHK-06	41	27	47	0.7
03X-31A0-2	R4	CHK-06	50	34	47	0.7
03X-46A2-2	R4	CHK-06	69	47	47	0.7
3-phase AC supply, 380 to 480 V						
03X-01A2-4	R0	CHK-01	2.2	1.1	4.2	6.4
03X-01A9-4	R0	CHK-01	3.6	1.8	4.2	6.4
03X-02A4-4	R1	CHK-01	4.1	2.3	4.2	6.4
03X-03A3-4	R1	CHK-01	6	3.1	4.2	6.4
03X-04A1-4	R1	CHK-02	6.9	3.5	7.6	4.6
03X-05A6-4	R1	CHK-02	9.6	4.8	7.6	4.6
03X-07A3-4	R1	CHK-02	11.6	6.1	7.6	4.6
03X-08A8-4	R1	CHK-03	13.6	7.7	13	2.7
03X-12A5-4	R3	CHK-03	18.8	11.4	13	2.7
03X-15A6-4	R3	CHK-04	22.1	11.8	22	1.5
03X-23A1-4	R3	CHK-04	30.9	17.5	22	1.5
03X-31A0-4	R4	CHK-05	52	24.5	33	1.1
03X-38A0-4	R4	CHK-06	61	31.7	47	0.7
03X-44A0-4	R4	CHK-06	67	37.8	47	0.7

I_{IN} = Nominal input current. When used in 480V network I_{IN} is 20% lower with rated power.

I_{TH} = Nominal choke thermal current

L = Choke inductance

Output chokes

Output choke decreases du/dt on the output and filters current spikes caused by voltage spikes. With an output choke it is possible to increase the motor cable length which could be otherwise limited due to a temperature increase resulting from current spikes and electromagnetic performance.

Type designation ACS355-	Frame size	Output choke	Cable length [m]
1-phase AC supply, 200 to 240 V			
01X-02A4-2	R0	ACS-CHK-B3	60
01X-04A7-2	R1	ACS-CHK-B3	100
01X-06A7-2	R1	ACS-CHK-C3	100
01X-07A5-2	R2	ACS-CHK-C3	100
01X-09A8-2	R2	ACS-CHK-C3	100
3-phase AC supply, 200 to 240 V			
03X-02A4-2	R0	ACS-CHK-B3	60
03X-03A5-2	R0	ACS-CHK-B3	60
03X-04A7-2	R1	ACS-CHK-B3	100
03X-06A7-2	R1	ACS-CHK-C3	100
03X-07A5-2	R1	ACS-CHK-C3	100
03X-09A8-2	R2	ACS-CHK-C3	100
03X-13A3-2	R2	NOCH-0016-6x	100
03X-17A6-2	R2	NOCH-0016-6x	100
03X-24A4-2	R3	NOCH-0030-6x	100
03X-31A0-2	R4	NOCH-0030-6x	100
03X-46A2-2	R4	NOCH-0070-6x	100
3-phase AC supply, 380 to 480 V			
03X-01A2-4	R0	ACS-CHK-B3	60
03X-01A9-4	R0	ACS-CHK-B3	60
03X-02A4-4	R1	ACS-CHK-B3	100
03X-03A3-4	R1	ACS-CHK-B3	100
03X-04A1-4	R1	ACS-CHK-C3	100
03X-05A6-4	R1	ACS-CHK-C3	100
03X-07A3-4	R1	NOCH-0016-6x	100
03X-08A8-4	R1	NOCH-0016-6x	100
03X-12A5-4	R3	NOCH-0016-6x	100
03X-15A6-4	R3	NOCH-0016-6x	100
03X-23A1-4	R3	NOCH-0030-6x	100
03X-31A0-4	R4	NOCH-0030-6x	100
03X-38A0-4	R4	NOCH-0030-6x	100
03X-44A0-4	R4	NOCH-0070-6x	100

Options External

A separate order line and type designation is required for any of these external options.

EMC filters

The ACS355's internal EMC filter is designed to meet category C3 requirements of EN/IEC 61800-3 standard. External EMC filters are used to enhance the drives electromagnetic performance in conjunction with its internal filtering. Maximum motor cable length depends on required electromagnetic performance, according to the table below.

Type designation ACS355-	Frame size	Filter type	Cable length ¹⁾ with external EMC filter			Cable length ¹⁾ without external EMC filter	
			C1	C2	C3	C3	C4
			[m]	[m]	[m]	[m]	[m]
1-phase AC supply, 200 to 240 V							
01X-02A4-2	R0	RFI-11	10	30	-	30	30
01X-04A7-2	R1	RFI-12	10	30	50	30	50
01X-06A7-2	R1	RFI-12	10	30	50	30	50
01X-07A5-2	R2	RFI-13	10	30	50	30	50
01X-09A8-2	R2	RFI-13	10	30	50	30	50
3-phase AC supply, 200 to 240 V							
03X-02A4-2	R0	RFI-32	10	30	-	30	30
03X-03A5-2	R0	RFI-32	10	30	-	30	30
03X-04A7-2	R1	RFI-32	10	30	50	30	50
03X-06A7-2	R1	RFI-32	10	30	50	30	50
03X-07A5-2	R1	RFI-32	10	30	50	30	50
03X-09A8-2	R2	RFI-32	10	30	50	30	50
03X-13A3-2	R2	RFI-33	10	30	50	30	50
03X-17A6-2	R2	RFI-33	10	30	50	30	50
03X-24A4-2	R3	RFI-34	10	30	50	30	50
03X-31A0-2	R4	RFI-34	10	30	50	30	50
03X-46A2-2	R4	RFI-34	10	30	50	30	50
3-phase AC supply, 380 to 480 V							
03X-01A2-4	R0	RFI-32	30	30	-	30	30
03X-01A9-4	R0	RFI-32	30	30	-	30	30
03X-02A4-4	R1	RFI-32	50	50	50	30	50
03X-03A3-4	R1	RFI-32	50	50	50	30	50
03X-04A1-4	R1	RFI-32	50	50	50	30	50
03X-05A6-4	R1	RFI-32	50	50	50	30	50
03X-07A3-4	R1	RFI-32	50	50	50	30	50
03X-08A8-4	R1	RFI-32	50	50	50	30	50
03X-12A5-4	R3	RFI-33	40	40	40	30	50
03X-15A6-4	R3	RFI-33	40	40	40	30	50
03X-23A1-4	R3	RFI-33	40	40	40	30	50
03X-31A0-4	R4	RFI-34	-	30	-	30	50
03X-38A0-4	R4	RFI-34	-	30	-	30	50
03X-44A0-4	R4	RFI-34	-	30	-	30	50

¹⁾ Internal EMC filter must be connected with the EMC screw in the drive.
When the filter is not connected the C4 maximum cable lengths are allowed to be used.

Low leakage current filters

Low leakage current filters are ideal for installations where residual current devices (RCD) are required and leakage current needs to be below 30 mA.

Type designation ACS355-	Frame size	Filter type	Cable length ¹⁾ with LRFI filter	
			C2	C4
			[m]	

Low leakage current filters, 3-phase AC supply, 400 V

03X-01A2-4	R0	LRFI-31	10	
03X-01A9-4	R0	LRFI-31	10	
03X-02A4-4	R1	LRFI-31	10	
03X-03A3-4	R1	LRFI-31	10	
03X-04A1-4	R1	LRFI-31	10	
03X-05A6-4	R1	LRFI-31	10	
03X-07A3-4	R1	LRFI-32	10	
03X-08A8-4	R1	LRFI-32	10	

¹⁾ Internal EMC filter must be disconnected by removing the EMC screw from the drive.

EMC standards in general

EN 61800-3 (2004), product standard	EN 55011, product family standard for industrial, scientific and medical (ISM) equipment	EN 61800-3/A11 (2000), product standard
Category C1	Group 1 Class B	1 st environment, unrestricted distribution
Category C2	Group 1 Class A	1 st environment, restricted distribution
Category C3	Group 2 Class A	2 nd environment, unrestricted distribution
Category C4	Not applicable	2 nd environment, restricted distribution

Compact PLC and AC drive starter kit

ACS355

-

01E

-

02A4

-

2

+

P924

ABB's programmable logic controller (PLC) and AC drive starter kit offer an out-of-box motor control in minutes.

The compact, yet powerful kit, targets small-scale machines and systems requiring PLC control and up to seven drives.

Easy ordering and fast startup

Providing PLC, AC drive and accessories as a package simplifies ordering and provides quick deliveries. The ordering code for the starter kit is ACS355-01E-02A4-2+P924. Please note that the starter kit is available only in the EMEA region.

A starter kit containing an AC500-eCo PLC and ABB machinery drive, ACS355 (0.37 kW), is intended for evaluation and customization (application programming). The kit contains a ready-made application program based on the AC500 function block library for drives, accessories, user documentation and Control Builder programming environment.

Ready-made reorder packages for ACS355 enables expansion of starter kit to a multiple drives system. AC500 product family offers several controllers for system scaling.

Benefits of the kit

- Control of a motor in minutes
- Easy ordering of PLC, AC drive and accessories as a kit from ABB's central stock
- Entry-level kit for learning the Control Builder programming environment based on CoDeSys
- Pre-engineered communication libraries for all ABB LV AC drives
- Ready-made HMI visualization
- Cost-efficient system expansion, since the same application program can be used for the entire AC500 PLC platform



Expertise at every stage of the value chain

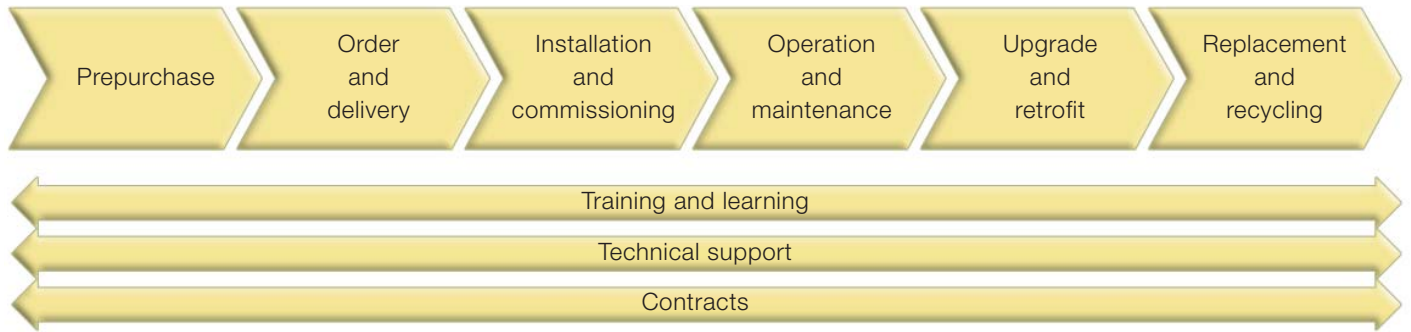

Whether you operate in industry, commerce or a utility your aims remain the same: to keep your motor-driven applications running consistently and efficiently. The life cycle services for ABB drives can help you achieve these aims by maximizing the uptime of your process while ensuring the optimum lifetime of ABB drives in a predictable, safe and low-cost manner.

The life cycle services for ABB drives span the entire value chain, from the moment you make the first enquiry about a drive through to its disposal and recycling. Throughout the value chain, ABB provides training and learning, technical support and contracts. All of this is supported by one of the most extensive global drive sales and service networks.

Secure uptime throughout the drive life cycle

ABB follows a four-phase model for the life cycle management of its drives. The life cycle phases are active, classic, limited and obsolete. Within each phase, every drive series has a defined set of services.

The four-phase drive life cycle management model provides you with a transparent method for managing your investment in drives. In each phase, you clearly see what life cycle services are available, and more importantly, what services are not available. Decisions on upgrading, retrofitting or replacing drives can be made with confidence.

ABB drive life cycle management model

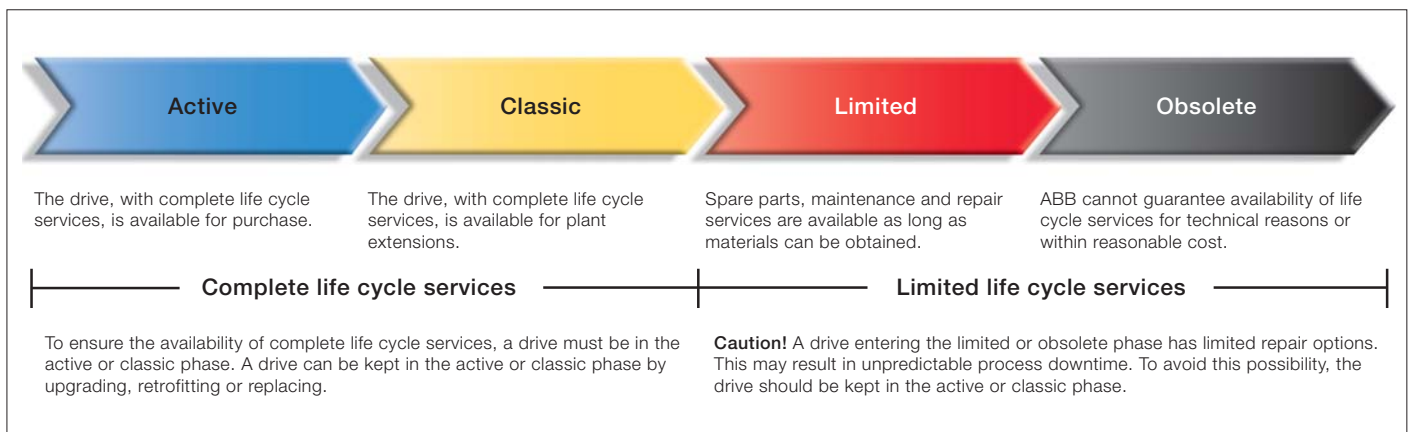

Contact us

For more information please contact your local ABB representative or visit:

www.abb.com/drives

www.abb.com/drivespartners

© Copyright 2013 ABB. All rights reserved.
Specifications subject to change without notice.

3AUA0000068669 REV D EN 26.4.2013 #16734